

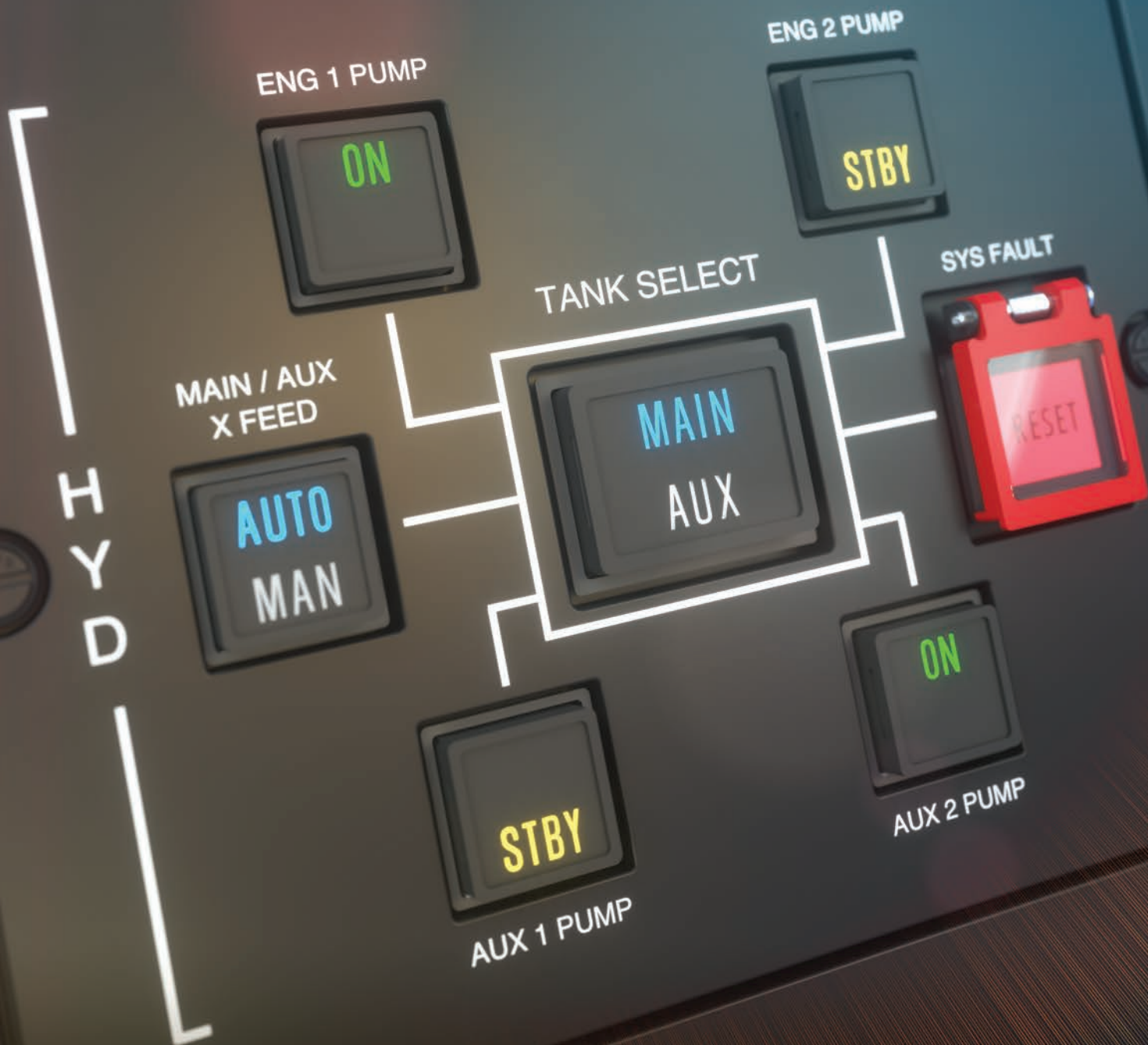

Advanced Lighted Pushbutton
Switches & Indicators





Applied Avionics

*Applied Avionics is the designer and manufacturer of
VIVISUN Advanced Lighted Pushbutton Switches and Indicators
and NEXSYS Avionics Interface Solutions.*

*Based in Fort Worth, Texas, Applied Avionics has focused
on reliable and innovative solutions serving the aviation,
aerospace, and military industries for over 50 years.*



VIVISUN Advanced Lighted Pushbutton Switches and Indicators are designed and manufactured to meet the highest quality and performance standards. VIVISUN products are utilized in military and commercial platforms worldwide and offer a broad range of specialized operator interface features focusing on legend readability, high reliability and innovative electronic functionality beyond basic switching.

12
NEXSYS
Component
Options

MIL-SPEC Qualified

DO-160 Tested

MIL-STD-3009 Compliant

Expanded Electronic Capabilities with NEXSYS® Component Technology

Coupled with NEXSYS Component Technology, design custom system-to-system interface solutions directly inside VIVISUN switches and indicators. Twelve unique NEXSYS solid-state components provide functionality that includes internal ARINC 429 converters/decoders, latching flip-flops, Boolean logic gates, relays and timers. Our in-house application engineers can assist in specifying parts that meet your exact design requirements.

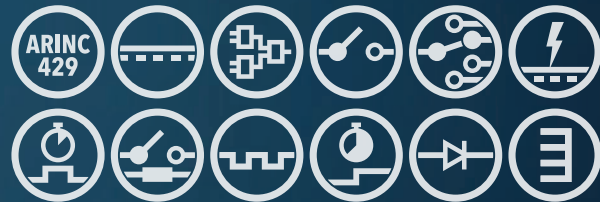

MIL-SPEC Qualified and DO-160 Tested

VIVISUN products are manufactured by Applied Avionics in our AS9100 certified facility in Fort Worth, Texas ensuring exceptional quality and superior performance. VIVISUN switches and indicators are fully qualified to MIL-PRF-22885 and are listed on the Qualified Products List (QPL). VIVISUN parts are also tested to the electrical, environmental, and electromagnetic specifications of RTCA/DO-160.

Superior Sunlight Readability and Night Vision Compliance

VIVISUN offers best-in-class display quality and flexibility for all pilot, crew and passenger ambient lighting environments. Sunlight readable displays meeting safety critical contrast ratios are available in fourteen colors. Native NVG (night vision goggle) compliance, per MIL-STD-3009, requires no after-market filtering or modifications.

Easy Online Part Configuration and Exceptional Customer Service

Specifying VIVISUN part numbers is easy using the Applied Avionics Part Configurator. Our secure, online system allows users to instantly generate part numbers and download a detailed specification sheet. Customer inquiries are answered directly by knowledgeable sales personnel and our paperless quotation process ensures timely and accurate order processing.

www.appliedavionics.com/configurator



LED Display Caps

Display Cap Sizes

VIVISUN switches and indicators offer two display cap size options as shown (actual size) below. Standard Square display caps offer a full range of advanced product options, while Large Rectangular display caps feature a larger viewing area. Both display cap sizes can be configured in a High Capacity, Compact or Short bodies.

Standard Square

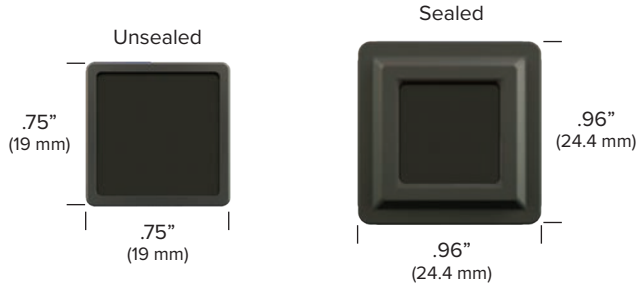

Large Rectangular

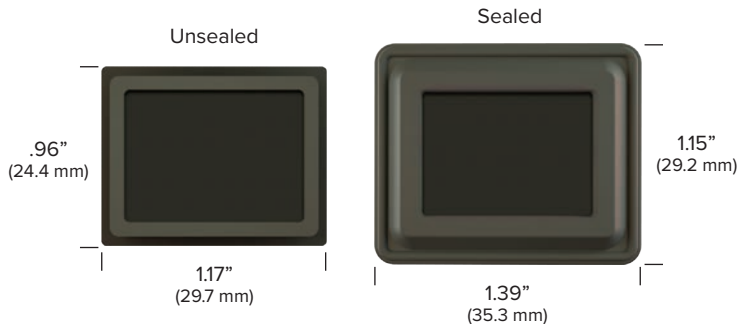

Both display cap sizes are available with an optional seal that prevents sand, dust and water from entering the switch and indicator body. The optional seal meets the requirements of MIL-PRF-22885 and MIL-STD-108 for drip-proof, watertight and splash-proof operation.

Display Segmentation

Display caps can be configured with up to four segments as shown below. Each segment can be independently controlled and specified with its own display type, legend and display color. VIVISUN switches and indicators can also be rotated and mounted at 90° to achieve a vertically stacked legend and additional layouts.

Standard Square



Large Rectangular

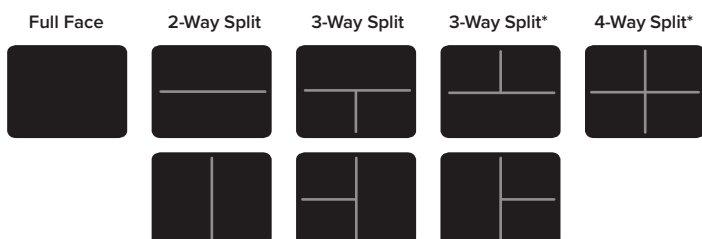

* Not available with Illumination Test Input

Display Lighting Colors

VIVISUN display caps can be configured in six aviation and eight NVIS lighting colors. While NVIS Red meets the requirements of MIL-STD-3009, NVIS Alt. Red offers a truer red hue that may be preferable in certain applications.

Aviation Colors*



Blue, Cyan, Green, White, Yellow/Amber, Red

NVIS Compliant Colors*



Blue, Green A, Green B, White, Yellow Class A, Yellow Class B, Red, Alt. Red

* Certain colors are not available for all display types.

Display Types and Sunlight Readability

Display caps can be configured in dead-face and visible legend display styles shown below. The Type S display type meets the most stringent MIL-PRF-22885 sunlight readability and contrast requirements. Type H is appropriate for applications that do not require full sunlight readability. Type D and Type N are similar, with Type N applicable for very low luminance non-dimmable applications. Except for Type W, display types can be different for each display segment. The typical luminance levels for each display type are shown at the rated voltage.

Dead-face (when Off)

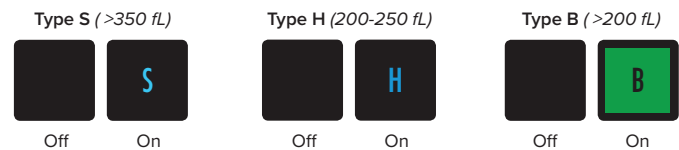

Visible White (when Off)

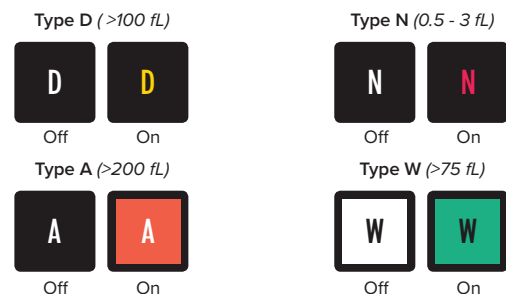

Fonts, Symbols and Custom Legends

Character fonts can be selected to optimize readability for different Display Types and character sizes (0.072" – 0.220"). Non-English language characters and custom symbols are also easily accommodated. The Part Configurator allows a preview of the final legend design. The following fonts are currently available:

GLOBE
ALT. GOTHIC

FUTURA
DIN 1451

GORTON
HELVETICA

Voltage Options

Standard Square and Large Rectangular display caps are available in voltage options as outlined in the table below.

Standard Square		Large Rectangular
+28 VDC +5 VDC	28 VAC 5 VAC 115 VAC	+28 VDC / 28 VAC

Display Circuit Options

Display caps are power efficient and can be specified to minimize the wiring required to illuminate the legend segments.

Standard Square	Large Rectangular
Common Cathode or Common Anode (DC) Single or Split Common Segment Interconnect Options Illumination Test	Polarity Insensitive Single or Split Common Segment Interconnect Options Illumination Test

Dimming Options

VIVISUN display caps are available with two options for lighting control.

Voltage Dimming

LED caps configured for Voltage Dimming use a patented advanced electrical circuit design which allows consistent, uniform dimming from daylight conditions to nighttime flying levels with a simple change to input voltage. Luminance for each display lighting color has been optimized for each display type to provide a consistent transition along the entire relevant voltage range.

Discrete Dimming *(available only in Standard Square display caps)*

LED caps configured with Discrete Dimming provide stepped dimming levels in a single display cap. Dimming levels are reached by applying various combinations of +28 VDC, Ground, or Open to two dimming mode control pins.

There are nine distinct dimming levels shown in the table below covering the entire range of Aviation and NVIS colors. Each cap can be configured with two levels (i.e. Sunlight / Aviation Night) or three levels (i.e. Sunlight / Aviation Night / NVIS Compliant).

Dimming Level Options		Typical Luminance (Full Face, Type S)	
Aviation Colors	NVIS Colors	Approx. Equivalent Voltage	Typical Luminance
Sunlight		+28 VDC	>350 fL
Day		+18-20 VDC	120 fL
Enclosure		+15-17 VDC	60 fL
Aviation Night		+13-15 VDC	15 fL
Low Night		+8-9 VDC	7 fL
Panel	NVG Compatible	+7-8 VDC	2 fL
Low Panel	NVG Compatible (1 fL)	+7.2 VDC	1 fL
—	NVIS Compliant	+6.55-7.0 VDC	0.1-1.0 fL
Minimum Panel	NVG Compliant (0.1 fL)	+6.55 VDC	0.1 fL



Fully Separable Display

Exclusive to VIVISUN Advanced Lighted Pushbutton Switches and Indicators, display caps are fully separable from the switch body. Separable display caps maximize reliability, ease installation and can provide cost saving opportunities by buying standard bodies that accept virtually any display cap. LED display caps are fully backward compatible with VIVISUN 95 Series incandescent display caps, meaning an LED upgrade can be as simple as buying new LED display caps to install in existing VIVISUN switch/indicator bodies.

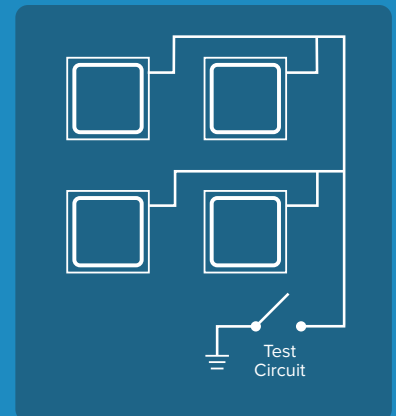

Illumination Test Pin and Blocking Diodes

VIVISUN display caps can be specified with internal segment diode isolation and a dedicated illumination test input allowing all legend segments to be illuminated simultaneously for test purposes. Alternatively, Standard Square display caps can be specified with only internal blocking diodes (no dedicated test input pin), which can prevent sneak paths.

Multiple display caps can be connected to the same test circuit for illumination of all display caps in a panel.

Switch and Indicator Bodies

Body Capacity

VIVISUN bodies are available in a High Capacity, Compact and a Short Body form factor. The different body options provide design flexibility for a full range of panel depth and termination requirements. The High Capacity and Compact Bodies use a solderless connector plug and offer up to four electrical switch poles. In addition, both the High Capacity and Compact bodies accept different combinations of NEXSYS components. The Short Body provides the shortest behind the panel depth option and offers solderable terminations for PCB assemblies or direct solder connections.

High Capacity Body

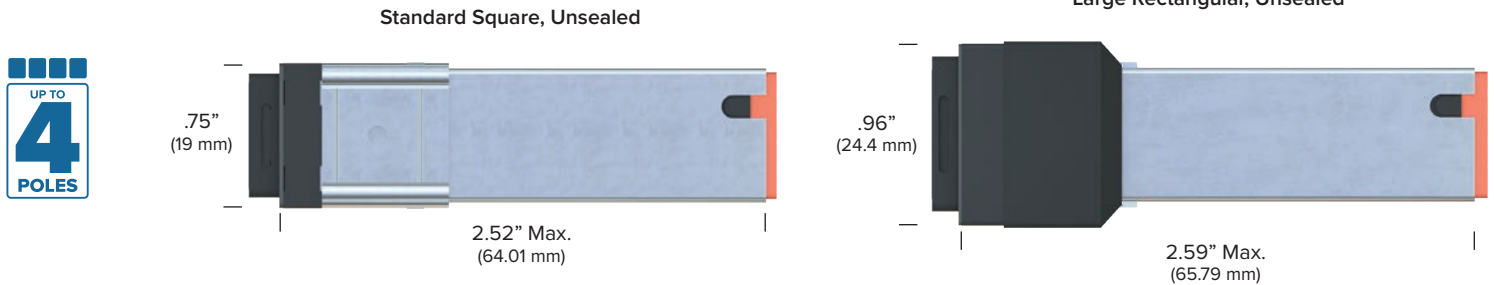

Compact Body

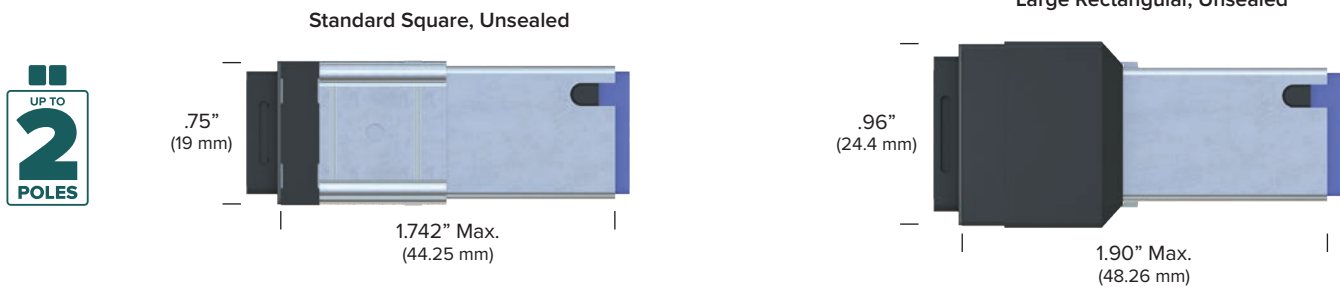

Short Body

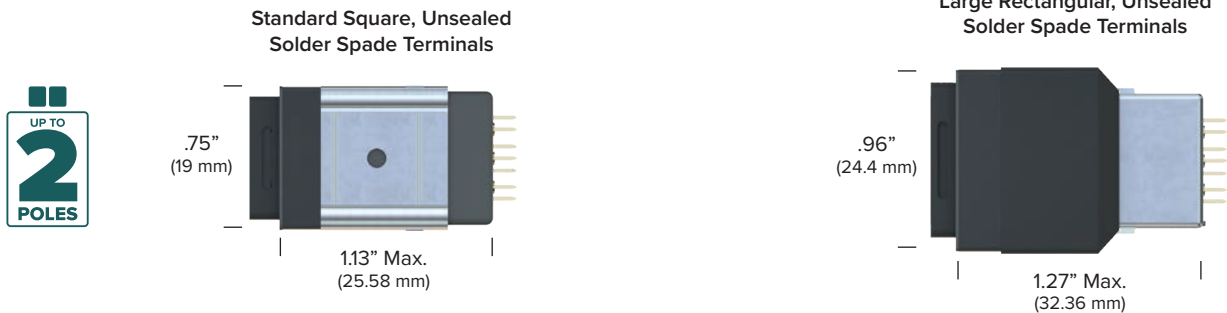

EMI Shielding

VIVISUN switches and indicators are available with an EMI/RFI attenuation option in accordance with MIL-PRF-22885. Shielding efficiency is not less than 60 dB over the frequency range of 100 to 1000 MHz and is available for the VIVISUN Compact and High Capacity bodies with Standard Square and the Large Rectangular display caps. The EMI/RFI option can be specified on the Part Configurator and is denoted in the completed part number.

High Shock/Vibration

For Operational Shock and Crash Safety, all VIVISUN switches and indicators are qualified to 20 G acceleration and 75 G Half-sine shock. As an option, sealed VIVISUN indicators and momentary action switches can be specified with High Impact Shock features that meet the specifications for MIL-STD-202 method 207.

Termination

VIVISUN bodies offer multiple termination options designed to address a combination of packaging efficiency and reduced installation labor. The solderless connector (22 pins for High Capacity; 14 pins for Compact) significantly reduces touch labor and utilizes industry standard MIL-C-39029/22-192 crimp contact sockets (ordered separately) on 20 - 24 AWG wires. Solderable connections on Short Body housings are available with turret, spade, and wire wrap/PCB terminals..

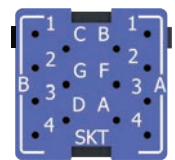

18-200
Connector Plug for Compact Bodies

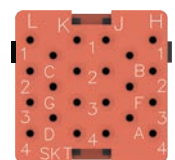

18-240
Connector Plug for High Capacity Bodies

Switching Options

Unlike touch screen technologies, VIVISUN switches provide the operator a distinct tactile response, giving the operator positive feedback upon actuation. VIVISUN switches utilize proven MIL-PRF-8805 qualified internal electromechanical micro switches rated at 7.5 amps resistive. When specified with gold contacts the switches are rated for low level dry circuit switching.

A VIVISUN switch body can be specified as momentary action or alternate action. Momentary action switch contacts are only closed while display cap is held in a depressed state. Alternate action display caps remain latched in a depressed state upon the first actuation (and switch contacts remain closed) and a second actuation is required to release the display cap and open the switch contacts. High Capacity bodies can accommodate up to four switch poles, while Compact and Short Bodies can accommodate up to two switch poles. All three bodies can also be ordered as annunciator/indicator with a stationary cap and no internal electromechanical switches.

- **Momentary Action**
- **Alternate Action**
- **Indicator Only**



Internal
Electromechanical
Switch

Ease of Installation

Each VIVISUN body includes all hardware required for mounting the body in the panel. For full installation instructions, refer to the VIVISUN Advanced Lighted Pushbutton Switches and Indicators Technical Guide (TG-LPBS-21).

For Standard Square bodies, a reversible mounting sleeve and optional front panel spacer are provided. To complete the installation process, the captive screw inside the switch body draws the internal cam assembly against the mounting sleeve (shown, right) and the sleeve against the back of the panel. The optional front panel spacer aligns the body with the front of a standard edge-lit panel and can be discarded if not needed.

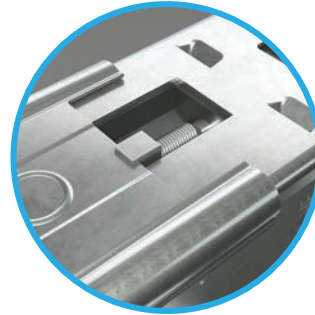

VIVISUN switch bodies
have integral captive
mounting hardware

For Large Rectangular bodies, a mounting sleeve and panel spacer is provided. For installations with a standard edge-lit panel, the panel spacer is placed in front of the panel to align the switch body with the front of the edge-lit panel. For all other Large Rectangular body applications, the panel spacer is placed behind the panel between panel and the mounting sleeve. To complete the installation process, the captive screws inside the body draw the internal cam assembly against the mounting sleeve and the sleeve against the back of the panel.

For sealed display cap installations, a drip-proof flange is provided with the body which mounts in front of the panel to accept the silicone rubber seal on the sealed display cap.

Panel Mounting

Correct panel mounting is necessary to achieve the expected reliability and tactile response of VIVISUN switches. The panel cutout and mounting hardware torque value are key elements in correct mounting and must meet the required size and tolerance. The required torque value for the integral mounting hardware is 18 - 25 in-oz and the cutout and tolerance values are referenced below. See Technical Guide (TG-LPBS-21) for horizontal and vertical center-to-center spacing for unsealed and sealed switches.

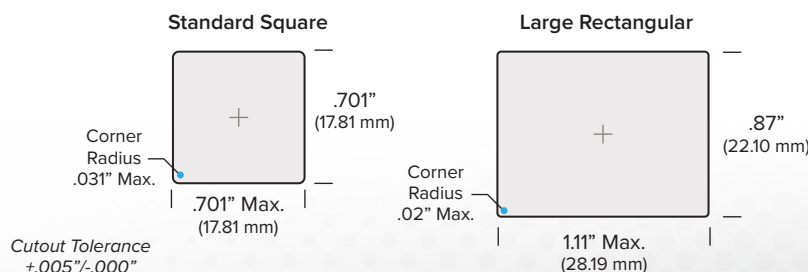

Self-Cleaning Contacts

VIVISUN switch bodies are designed for maintenance free operation and are rated for extreme environmental conditions and electrical load flexibility. The body has self-cleaning contacts which is an exclusive VIVISUN feature, assuring continuity between the body and the Display Cap each time the switch is actuated.



Panel Adapters

There are situations where an existing panel cutout needs to be adapted to accommodate a VIVISUN switch or indicator. VIVISUN offers a complete line of panel adapters that can transform an existing oversized panel cutout to the correct cutout for properly mounting a VIVISUN switch. These adapters are "captured" by the existing switch mounting hardware and are virtually unnoticeable once installed. Several common panel adapters are stocked for immediate delivery and provide a cost-effective alternative to reworking the panel.



NEXSYS Component Technology offers unparalleled flexibility in creating optimal size, weight and power solutions for designs involving:

- Cabin Management Systems (CMS)
- Flight Management Systems (FMS)
- In-Flight Entertainment Systems (IFE)
- Navigation Systems
- Internal Communication Systems (ICS)
- Environmental Control Systems (ECS)
- Power Distribution Systems

VIVISUN switches with internal NEXSYS components provide system-to-system interface options that reduce cost and delivers quickly with flight-ready certification.

Applied Avionics' application engineers are available to provide the support you need to design custom electronic and digital logic circuits using NEXSYS Component Technology.

Call or e-mail us today for help with your next project.

+1 (888) 848-4786

sales@appliedavionics.com

ADVANCED

Design custom electronic interface solutions directly inside VIVISUN Lighted Pushbutton Switches using  Component Technology

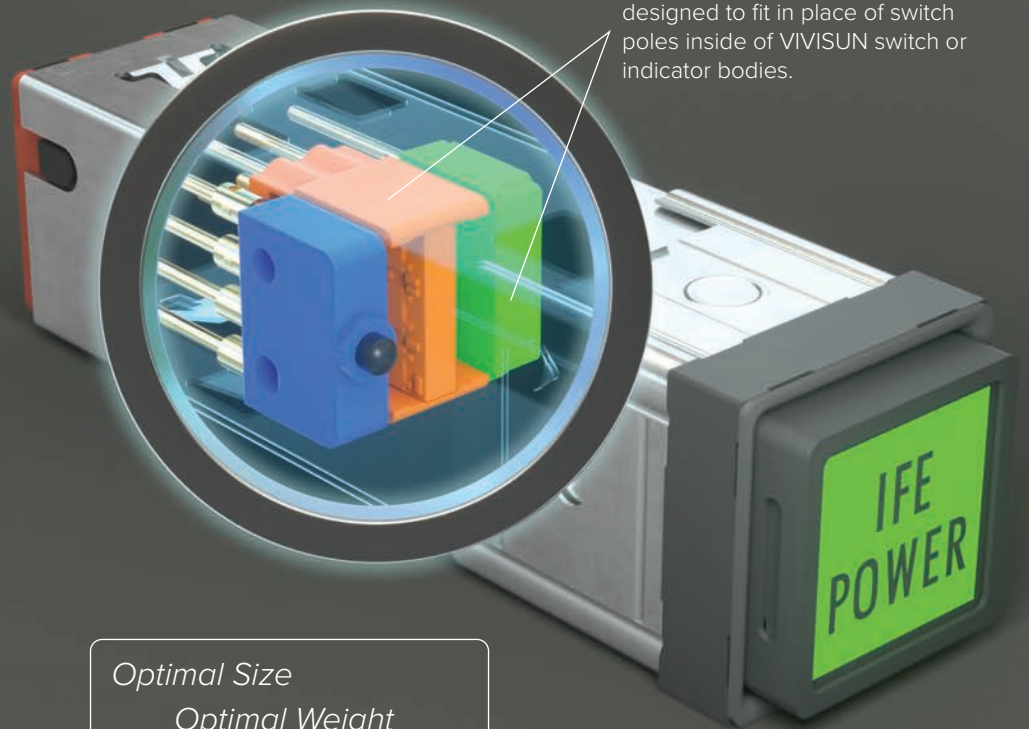

Optimal Size
Optimal Weight
Optimal Power

No Software
No Firmware

Here's what Electrical Systems Design Engineers are saying about NEXSYS Component Technology...

I was able to use the innovative NEXSYS Component Technology, from Applied Avionics, to solve a problem that arose late in the testing phase. The robust, lightweight and configurable design allowed for a design change that was quickly implemented and with minimal impacts to the aircraft or schedule.

– Paul R., Electrical Systems DER

NEXSYS® Integrated Electronic Components

NEXSYS Component Technology offers a number of electronic components that can be directly integrated into switch bodies and NEXSYS Modules that when utilized together can easily add additional system capabilities and provide tailored system integration solutions. Following is a list of the available NEXSYS components.



ARINC 429 Signal Converter

ARINC 429 signal converters are available in three configuration types:

1. SR429/1M, one discrete output from a single data bit and label. The internal fail sense circuitry includes a Health monitor and additional inputs to provide a failure detection interface for external discrete output.
2. SR429/4M, up to four primary and four additional discrete outputs, each from one data bit on a single label. Additional bit selection options include inverted bits, Health/Watchdog monitor, and the decoding of SSM bits.
3. SR429/4D, up to eight decoded outputs that are the binary decode of two or three bits on a single label. Additional bit selection options include discrete inputs, and Health/Watchdog monitor.



Pulse/Timer

Dual-channel, independent outputs, each triggered by a specified edge transition (falling/rising) detected by the Inputs. Each channel produces a "One-Shot" pulse output, specified as either active High Impedance or Ground, and the time interval options range from 125 ms to 20 seconds.



Time Delay

Time Delay active output that features options ranging from 125 ms to 4 hrs. Input trigger options include Ground, High Impedance, +28 VDC, or unit power-up.



Electronic Latch

Orthogonal (Flip-Flop circuit) and Blink (1 Hz) outputs controlled by Toggle, Set, and Reset inputs. The solid-state electronic latching circuitry provides an alternative to mechanical alternate-action or electromagnetic switches.



Electronic Rotary

Sequentially increments through a loop of up to four latched output states. An active state can be reset by an external input or cycling unit power.



Current Sensor

Current sensing input with integrated resistance that triggers an active output when a DC under or overcurrent setpoint is exceeded. Current sensing options range from 10 mA to 1000 mA (1 A).



Square Wave Oscillator

Externally controlled square wave oscillator with frequency options ranging from 0.25 Hz to 500 Hz. The active output oscillates between High Impedance and Ground.



Terminal Block

Four interconnected terminals that can occupy any unused switch/indicator or module position, increasing design efficiency by minimizing external splices.



Solid State Relay

Single and Combination Normally Open (NO), and Normally Closed (NC) solid-state switching, available in three voltages (Single SSR) with opto-isolated inputs and outputs for circuit buffering. Ideally suited to invert signal polarity, convert voltages, logic level signals, and create basic digital logic circuits, for example, AND or OR logic gates.



Defined Logic (Boolean)

Digital logic gates that provide multiple channels, cascaded levels, and binary decode solutions for electronic signals. Discrete Boolean options include AND, NAND, OR, NOR, EXOR, EXNOR, NOT (Inverter), and BUFFER.



DC Voltage Sensor

DC voltage sensing input that is triggered by an under or overvoltage setpoint. The input options range from + 50 mVDC - 48 VDC. For voltages up to + 1.0 VDC, the Voltage Sensor may be used as a current sensor when combined with an external shunt resistor.



Diode Pack

Two independent diodes packaged together to increase design efficiency, provide sneak path isolation, and diode logic gate functions. Configured as either commercial (1N6484) or military (1N5621JANTX).

NEXSYS Component Technology *has dramatically reduced my development time and costs. I've been able to eliminate custom electronic assemblies and the associated DO-160 environmental testing. My engineering effort has been reduced from man-months to a few man-days on most projects.*

– Dave L., Principal Engineer – Avionics

NEXSYS® Component Configurations inside VIVISUN® Switches and Indicators

NEXSYS Component Technology is available inside VIVISUN Compact and High Capacity bodies, as well as inside NEXSYS Modules.

Inside a VIVISUN body, NEXSYS components can occupy positions that are not already occupied by an electromechanical switch. Each NEXSYS component is either a Series A (shown in green), 4 pin device; Series C (shown in orange) or a Series N (shown in red), 8 pin device; or Series R (shown in purple), 12 pin device. The table below shows the series designation of each NEXSYS component.

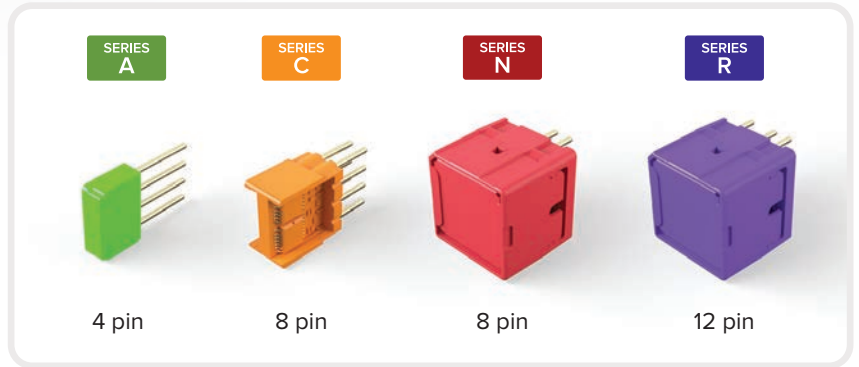

ARINC 429 Single-bit Converter (SR429/1M)	SERIES N	Electronic Latch (EL1, EL2)	SERIES C	Square Wave Oscillator (CT1)	SERIES A
ARINC 429 Multi-bit Converter (SR429/4M)	SERIES N, SERIES R	Electronic Rotary (ER1)	SERIES C	Time Delay (TD1)	SERIES A
ARINC 429 Multi-bit Decoding Converter (SR429/4D)	SERIES N, SERIES R	Pulse/Timer (PT1)	SERIES C	Voltage Sensor (VSD1, VSD2)	SERIES A
Current Sensor (CS1)	SERIES A	Solid State Relay (SSR1, SSR2)	SERIES A	Diode Pack (DP2C, DP2M)	SERIES A
Defined Logic (DL1, DL2, DL3, DL4)	SERIES C	Solid State Relay (SSRC)	SERIES C	Terminal Block (TB4)	SERIES A

Inside a VIVISUN Compact Switch or Indicator Body



Compact bodies provide two available, 4 pin positions (A and B in the diagram). Each Series A (4 pin) component can occupy one of the available two positions that is not already configured with an electromechanical switch pole (equivalent a 4 pin device).

Compact bodies cannot accommodate Series C, Series N or Series R components. Applications that require the use of Series C, Series N or Series R components must be configured in a VIVISUN High Capacity body.

Unoccupied positions will be configured with an Open spacer.

Compact bodies with NEXSYS components require the use of Connector Plug (P/N 18-442).

* This connector plug is different than the plug required for switch/indicator bodies that do not contain NEXSYS components.

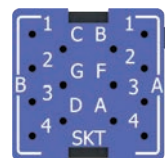

18-442 NEXSYS Connector Plug

Inside a VIVISUN High Capacity Switch or Indicator Body



High Capacity bodies provide four available, 4 pin positions (H, J, K and L in the diagram above). Each Series A (4 pin) component can occupy one of the available four positions that is not already configured with an electromechanical switch pole (also a 4 pin device).

High Capacity bodies can accommodate one Series C or Series N (8 pin) component that will occupy the middle two positions (J and K), leaving positions H and L available for either two additional Series A components, two electromechanical switches or one of each.

High Capacity bodies can accommodate one Series R (12 pin) component that will occupy three positions (J, K and L), leaving position H available for either one Series A component or one electromechanical switch. Unoccupied positions will be configured with an Open spacer.

High Capacity bodies with NEXSYS components require the use of Connector Plug (P/N 18-440).

* This connector plug is different than the plug required for switch/indicator bodies that do not contain NEXSYS components.

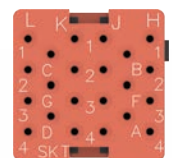

18-440 NEXSYS Connector Plug

NEXSYS® Application Examples

To help system engineers understand the opportunities that NEXSYS Component Technology offers, Applied Avionics has published a library of applications accessible on our website.

ICS Cabin Call/Flight Deck Isolate

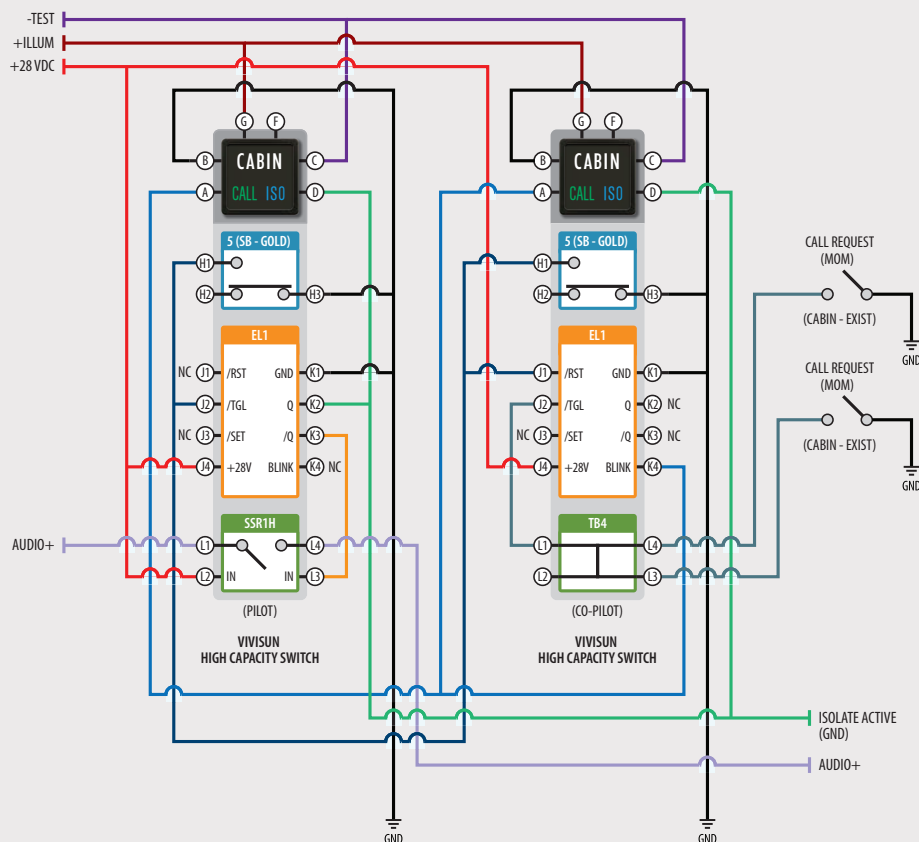

This application details an aircraft internal communication system (ICS) that connects the flight deck with the cabin. The design provides flexibility that allows flight deck to isolate from cabin audio at any time, while still allowing the cabin to initiate a call.

The design uses two switches that include VIVISUN High Capacity bodies which each house momentary switches and NEXSYS Electronic Latches (EL1). NEXSYS Solid State Relay (SSR1H) and Terminal Block (TB4) components are utilized as well. The EL1 components control the individual CALL and ISO states, while the SSR1H is used to interrupt the audio line when in the ISO state. The TB4 buses together the call request signals from the existing cabin momentary switches.



Scan for Full Details

WAAS Approach (Level of Service)

This application depicts a WAAS Approach indicator with a built-in ARINC 429 Multi-Bit Decoding Converter. The converter reads and decodes the selected label and bits. Once decoded, the data is output as separate discrete signals that are used to illuminate legends which correspond to the current level of service.

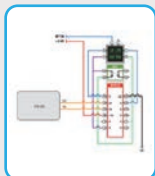

Scan for Full Details

Electronic Switch Guard with Time Delay

This application depicts a mission power switch with an electronic switch guard. The mission power switch contacts must be held closed for 3 seconds to activate the power relay. Inadvertent contact with the switch for less than 3 seconds will be ignored preventing power from being applied accidentally to downstream mission buses.

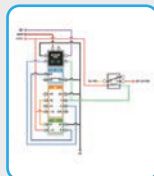

Scan for Full Details

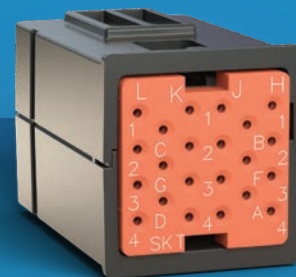

NEXSYS® Modules

NEXSYS components can also be packaged inside a NEXSYS Module to provide maximum installation flexibility.

NEXSYS Modules are useful for behind-the-panel designs that do not require an operator interface or can be used to provide additional NEXSYS component capacity in switch or indicator-based applications.

By combining VIVISUN switches and NEXSYS Modules, unlimited custom interface solutions can be delivered with off-the-shelf speed.

These modules can be installed in-line with the wire harness in a flame retardant boot, mounted with a dedicated bracket (illustrated below) or installed in a Type 1 rail.

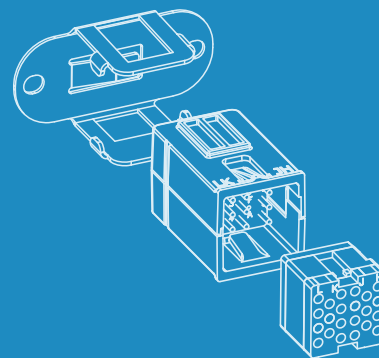



Accessories

Applied Avionics offers a number of switch guards, panel plugs, and panel adapters as well as other tools to ensure an easy installation of VIVISUN switches and indicators. Contact Sales for the complete line of available accessories.

Switch Guards (Partial Listing)

Panel Plugs

Panel Adapters



Switch Guard, Part Numbers

Color	Standard Square		Large Rectangular	
	Unsealed	Sealed	Unsealed	Sealed
Black	17-670	17-673	21-601	21-604
Yellow	17-671	17-674	21-602	21-605
Red	17-672	17-675	21-603	21-606
Clear	17-183	17-143	–	–

Panel Plugs, Part Numbers

Color	Standard Square	Large Rectangular
Black	18-258	21-585
Dk. Gray	18-260	21-586
Lt. Gray	18-266	21-587

Panel Adapters, Part Numbers

Standard Square	
.756 to .701	18-269
.810 to .701	18-247
.925 to .701	18-236
.940 to .701	18-632
.866 x 1.106 to .701	18-268

Installation Tools & Connector Plugs



18-234
Connector Plug
Extraction Tool

18-216
Crimp Socket
Wire Removal Tool

17-150
Cap Extraction Tool

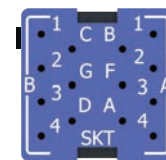

18-200
Connector Plug*
(For Compact Bodies)

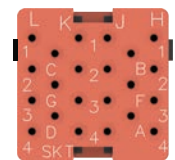

18-240
Connector Plug
(For High Capacity Bodies)

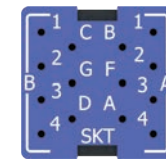

18-442
NEXSYS Connector Plug*
(For Compact Bodies
with NEXSYS components)

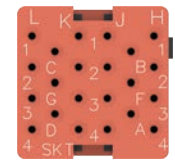

18-440
NEXSYS Connector Plug*
(For High Capacity Bodies
with NEXSYS components)

*Sealing Plugs are included with connector plugs.
Crimp Sockets are ordered separately.

Hardware Installation Tool Kit

18-194 – Includes: (1) 18-234 Connector Plug Extraction Tool, (1) 18-216 Crimp Socket Wire Removal Tool, (1) 17-150 Cap Extraction Tool

Crimp Sockets

18-219
MIL-C-39029/22-192, Pack of 25
(not included w/ Connector Plug)

Qualifications Summary

The key environmental and electrical qualification levels for VIVISUN switches and indicators are listed below. Refer to the Technical Guide (TG-LPBS-21) for the a complete listing of environmental and electrical test qualifications.

Environmental Qualifications (Partial Listing)

Test Description	Specification	Section	Category	Reference Levels
Altitude	RTCA/DO-160 MIL-STD-202 MIL-STD-810	4 105C 500	F2 & A2 B Procedure II	-15,000 feet, +55,000 feet (some units +70,000 feet)
Temperature	RTCA/DO-160 MIL-STD-810	4 501/502	F2 Procedure III	-55°C and +85°C (Illuminated Indicator rated at +71°C)
Temperature Variation	RTCA/DO-160 MIL-STD-202 MIL-STD-810	5 107 503	S2 A 1	5 cycles -55°C /+85°C
High Temperature Survival (Non-operating)	MIL-STD-202	108A	A	+85°C, 96 hours (Switch Module) +125°C, 96 hours (Electronic Unit only)
Humidity	RTCA/DO-160 MIL-STD-202	6 106	B N/A	240 hours, +65°C, > 90% RH
Operational Shock and Crash Safety	RTCA/DO-160 MIL-STD-202 MIL-STD-810	7 213 516	B B Procedure V	20 G Sawtooth, 75 G Half-Sine 75 G Half-Sine
Acceleration	RTCA/DO-160 MIL-STD-202 MIL-STD-810	7 212 513	B A Procedure III	20 G, 3 axis
Vibration	RTCA/DO-160 MIL-STD-202	8 204	R,U B	10-2000 Hz, 10 G 10-2000 Hz, 15 G
Waterproofness Seal (Sealed Switch)	RTCA/DO-160 MIL-PRF-22885	10 4.7.20	R Splash-proof	15 gal/min
Sand and Dust (Sealed Switch)	RTCA/DO-160 MIL-STD-202	12 110	D N/A	Silica media

Electrical Qualifications (Partial Listing)

Test Description	Specification	Section	Category	Reference Levels
Power Input Aircraft Power (DC)	RTCA/DO-160	16.6; except as noted below	A and B	
		16.6.1.3 (Mom. Power Interrupt)	A and B	200 ms / 50 ms dropout (CS, DL, EL, ER, PT, SR429/4, VS)**
			B	50 ms dropout (CT, SR429/1, TD)**
			N/A	No digital circuitry (DP, SSR, TB)**
	16.6.1.5, 16.6.2.2	B	Tests not applicable to Category A	
	MIL-STD-704	LDC (102, 301, 401, 501, 601, 602)	N/A	N/A
Spike	RTCA/DO-160	17	A	Power, 600 V, 10 us, 50 ohm 400 V, 5 us, 5 ohm
RF Conducted Susceptibility*	RTCA/DO-160 MIL-STD-461	20 CS114	Y Curve 5	300 mA, 10 kHz-400 MHz DO-160 Frequency Set
RF Radiated Susceptibility*	RTCA/DO-160 MIL-STD-461	20 RS103	Y 200 V/m	200 V/m, 2 MHz-18 GHz DO-160 Frequency Set
RF Emissions	RTCA/DO-160 MIL-STD-461	21 CE102	P	
Damped Sinusoidal Transient*	RTCA/DO-160 MIL-STD-461	22 CS116	XXK3L3 N/A	Waveform 3, 600 V, 1 MHz, 10 MHz 0.01 - 100 MHz, 1 - 10 A
Lightning Induced Transient*	RTCA/DO-160 MIL-STD-461	22 CS115	XXK3L3 N/A	Waveform 5A, 750 V, 120 us 30 ns, 5 amp
Dielectric Withstanding	MIL-STD-202	301	N/A	1000 VAC - Connections to case
Electrostatic Discharge	RTCA/DO-160 MIL-STD-461	25 CS118	A 4	15,000 V, 150 pf, 330 ohms

* Stated EMC performance based on tests performed on an individually monitored component using unshielded cables as defined by the applicable EMC test document. The EMC performance of an installed system using NEXSYS components can be dependent on the actual installation environment and interconnection method.

** Key to Abbreviations Above:

CS=Current Sensor, CT=Square Wave Oscillator, DL=Defined Logic, DP=Diode Pack, EL=Electronic Latch, ER=Electronic Rotary, PT=Pulse/Timer, SR429/1=ARINC 429 Signal Converter (1M), SR429/4=ARINC 429 Signal Converter (4M and /4D), SSR=Solid State Relay, TB=Terminal Block, TD=Time Delay, VS=Voltage Sensor

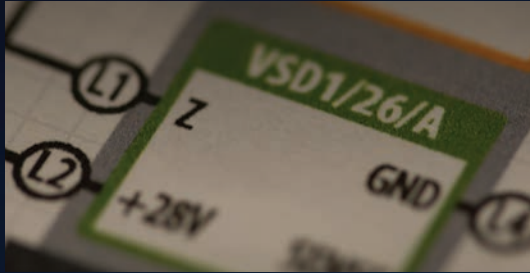

NEXSYS® Application Support

Including NEXSYS Component Technology in VIVISUN switches and indicators creates an opportunity to design custom control circuits within a familiar form factor.

NEXSYS application support is available to assist designers in selecting the correct combination of NEXSYS components. NEXSYS application engineers can provide wiring diagrams, LTSpice® simulations and can help specify a complete, ready-to-order part number.



Easy 24/7 Online Part Configuration

The Applied Avionics Part Configurator is available online 24 hours a day, 7 days a week and simplifies the process of specifying part numbers.

Once a part is configured, a part specification sheet will confirm part details and is available for download as a PDF.

Registered users of the Part Configurator have access to additional features, such as Quote Basket and the Part History from all users of their company.

Questions? Call Us.

+1 (888) 848-4786

Visit us online at www.appliedavionics.com

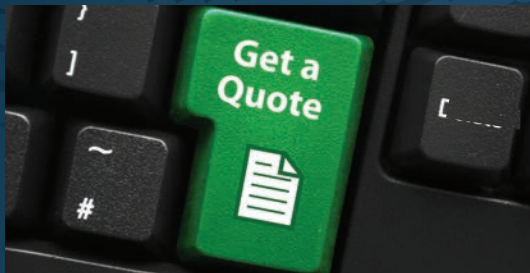

Request Price Quotations

Design engineers cannot afford to wait on routine pricing information. The quotation process for VIVISUN switches is paperless and simple via the online Part Configurator.

To request pricing information on existing part numbers, email your configured part number, quantity and your contact and company information to sales@appliedavionics.com.

Our goal is to provide a quick response to requests for pricing. Customers can expect a reply within one business day from the time of request.



Technical Sales Support

Applied Avionics is committed to exceeding your expectations through all phases of your project, from concept through delivery and installation.

Technical sales resources are available worldwide via email and telephone to provide full support of your VIVISUN and NEXSYS products.

Call or email us today to learn more about VIVISUN Advanced Lighted Pushbutton Switches and Indicators.

Applied Avionics

3201 Sandy Lane, Fort Worth, Texas, USA 76112 – (888) 848-4786