

Installation Manual and Users Guide

AAI-DCU120-DOC-INST

Revision 04

Applied Avionics

This document is a general Installation Manual and User's Guide. For a specific DCU120-[] part number (DCU120-[]-XXXXX), this information will be supplemented with a Customer Application Specification which will contain specific wiring and functionality for the specific part number.

Revision History

Date	Revision	Author	Purpose
2/16/2023	01	Loren Jensen	Initial release
3/1/2023	02	Loren Jensen	Added Rev Number for DO-178, DO-160; Added Table of Acronyms; Added dimension clarifications; Added notes to Top Level Drawing; Amended Appendix E
3/24/2023	03	Kylie Breeding	Updated part markings for all Top Level Drawings in Appendix A and in Section 2
9/19/2023	04	Kylie Breeding	Updated DCU120-M1-XXXXX (in Appendix A) to Rev F per ECR 4591 release. Added flammability to Appendix E.

Table of Contents

SECTION 1: PRODUCT OVERVIEW 5

CERTIFICATION 5

OVERVIEW 5

SIMPLIFIED BLOCK DIAGRAM 6

SECTION 2: OPERATING INSTRUCTIONS..... 7

OVERVIEW 7

PINOUTS 7

POWER AND GROUNDING..... 7

PART MARKING 8

SECTION 3: INSTALLER REQUIREMENTS..... 8

SECTION 4: LIMITATIONS 9

SECTION 5: FUNCTIONAL DESCRIPTION 10

CONFIGURATION FILE (CF) 10

INPUTS AND OUTPUTS..... 10

ARINC 429 10

DISCRETE INPUTS..... 10

DCU120-S SPECIFIC INPUTS AND OUTPUTS..... 10

ANALOG INPUTS 11

DISCRETE OUTPUTS 11

RS-232 11

SECTION 6: NON-TSO FUNCTIONS 12

DATA BUS BRIDGING 12

DATA CONCENTRATION..... 13

SECTION 7: CONTINUED AIRWORTHINESS..... 14

TABLES

TABLE 1 – ACRONYMS 15

APPENDICES

APPENDIX A – TOP LEVEL ASSEMBLY DRAWINGS..... 15

APPENDIX B – MICD..... 18

APPENDIX C – PINOUT BY FORM FACTOR 31

APPENDIX D – PERFORMANCE STANDARDS 34

APPENDIX E – ENVIRONMENTAL AND ELECTRICAL QUALIFICATION LEVELS 36

Table 1 - Acronyms

Acronym	Definition
AAI	Applied Avionics, Inc.
CF	Configuration File
COTS	Commercial Off the Shelf
DAL	Design Assurance Level
FAA	Federal Aviation Administration
GPIO	General Purpose Input/Output
I/O	Input/Output
OFP	Operational Flight Program
OPR	Open Problem Report
QPL	Qualified Products List
SDI	Standard Digital Interface
TSO	Technical Standard Order
TSOA	Technical Standard Order Authorization

Section 1: Product Overview

Certification

Applied Avionics, Inc. has been granted an **Incomplete** Technical Standard Order Authorization (TSOA) for the design and manufacture of the DCU120-S, DCU120-M1, and DCU120-B under **TSO-C113b**. As an Incomplete TSOA, only certain performance standards described in TSO-C113b are met, as described in **Appendix D**. This TSOA means that the article meets a minimum performance requirement independent of the article's intended installation on an aircraft. The installer/operator must obtain a separate FAA approval to install the article on the aircraft.

The embedded software in the DCU120-[] has been certified to DO-178C DAL-A. The functional hardware has been certified to DO-254 DAL-D. Environmental and Electrical Qualifications levels under DO-160G are listed in **Appendix E**.

Overview

The primary function of the Display Communications Unit (DCU120) is to provide flight crew visual information. Information from the DCU120 can be displayed directly through an integral multi-legend fixed display (Model DCU120-S) or the information from the DCU120 can be used to drive external annunciators and displays (Models DCU120-M1 and DCU120-B).



Figure 1: DCU120 Models

Each of the DCU120-[] models use common internal hardware to manage the inputs and outputs and performs the primary data processing function using a COTS microcontroller affixed to a circuit board. In all models, the microcontroller will have identical software loaded that can perform a wide variety of definitive operations. For each specific unique application, a factory set Configuration File (CF) is required to establish the specific input, function, and output configuration to the core software. Due to physical size constraints, the number of I/O varies by model.

THIS INSTALLATION MANUAL IS DESIGNED TO BE USED IN CONJUNCTION WITH A CUSTOMER SPECIFICATION APPLICATION WHICH WILL CONTAIN DETAILS OF THEIR SPECIFIC CUSTOMER INSTALLATION, INCLUDING SPECIFIC WIRING.

The DCU120-S provides the microcontroller capability housed in a traditional switch/indicator type body with an illuminated cap. The cap colors and legend are configurable at time of manufacture. This display cap is the same part used in the existing APPLIED AVIONICS pushbutton switch assembly that is qualified to MIL-PRF-22885/108 and listed under the MIL-PRF-22885 Qualified Products List (QPL).

The DCU120-M1 and DCU120-B provides the microcontroller capability housed in a rail mountable enclosure and a fixed metal enclosure respectively.

Simplified Block Diagram (All Models)

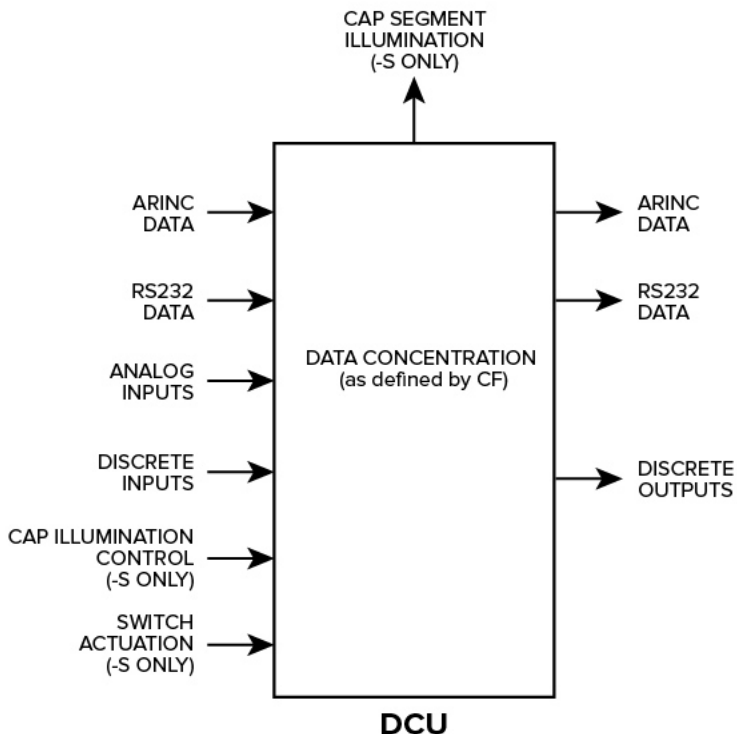

Section 2: Operating Instructions

Overview

Each specific DCU is factory programmed with a Configuration File (CF) to monitor the specified inputs and update the specified outputs as described in the CF.

Once wired and mounted during installation, a DCU120-S will have an illuminated cap providing visual indications to the operator during operations without additional human interaction. Additionally, if the DCU120-S form factor is configured with an internal momentary switch (specified at the time of manufacture), the operator (i.e., pilot) may interface with the DCU120-S by pressing the illuminated cap. The action that the DCU120-S software will take upon a switch activation will be specified in the CF.

Once wired and mounted during installation, a DCU120-M1 and DCU120-B will not have any other human interface during operations.

The DCU120 will be energized when power is provided to Pin 22 and the unit is properly grounded (Pins 18 and 19). There is no on/off switch on the DCU120.

Pinouts

The external pinout for each of the models is shown in Appendix C.

The pinout for each of the models vary slightly. DCU120-S and DCU120-M1 have several external pin connections that can be specified as either a discrete output or discrete input, corresponding to the purpose of that pin in the Configuration File and Customer Application Specification.

Most Customer Application Specifications will NOT use all of the available pinouts in a specific application. Installer shall refer to the Customer Application Specification for the specific pinouts used in given application.

Active pins shall be wired per **Appendix B**. Pins used in a specific customer application shall be detailed in the Customer Application Specification.

Power and Grounding

Operating Voltage: 18 – 33 VDC (200ms power dropout protection). Unit power shall be wired to Pin 22.

Grounding: Continuous Grounding to Pins 18 and 19 is required for proper operation.

Part Marking

The DCU120-[] family of devices will be marked in accordance with TSO-C113b Section 4, SAE AS8034C Section 3.10, and 14CFR45.15(b),(d).

Each device shall be marked with:

- Company Name
- TSO-C113b INCOMP
- Part Number
- Serial Number
- Date Code

Example Part Marking

Applied Avionics
 TSO-C113b INCOMP
 DCU120-S-A34T6
 BSN: 1946S00230
 DC: 2026

The Part Number will include the model number and a unique alphanumeric configuration identifier. The configuration identifier will be linked to a configuration database that will identify the specific configuration details at the time of manufacture including, software release, hardware release, configuration file load, hardware configuration, and, in the case of Model DCU120-S only, other manufacturing details related to the integral illuminated cap such as legend, lighting color, and lighting type.

Refer to **Appendix A** for the location of the part marking on each form factor.

Additionally, the Individual part packaging will be marked with:

- Part Number
- TSO-C113b INCOMP
- Manufacturers Name
- Weight
- Environmental categories per RTCA/DO-160G

Section 3: Installer Requirements

The DCU120-S is typically mounted in a panel allowing human-machine interface.

The DCU120-M1 is typically mounted remotely (i.e. away from instrument panel in an M81714/5 rail).

The DCU120-B is typically mounted remotely (i.e. away from instrument panel).

Installation details and the applicable wiring method for each model are located in **Appendix B**. Installer is responsible for selecting the appropriate location within the aircraft.

Special tools/connectors required for installation are described fully in **Appendix B** and are listed here for reference:

Cap Extractor Tool (AAI P/N 17-150); -S Model

Connector Plug (AAI P/N 26-602); -S and -M Models

Crimp Sockets (Amphenol Aerospace 2M809-002 (Type 23)); -S and -M Models

Wire Inserter/Extractor (Glenair 809-088); -S and -M Models

Connector Plug Extraction Tool (AAI P/N 18-234); -S and -M Models

Each Customer Application Specification will be different, and the Installer shall refer to the Customer Application Specification for the specific active pinouts used in a given application. The connector interface and specific functions of each pin for each form factor are located in **Appendix C**.

Section references below refer to AS8034 which contain the performance standards for TSO C113b.

3.11 Display

Installer shall determine the task essential information being displayed on the display cap, including legend (symbol/text, font, and font height), color, display type (i.e., deadface, illuminated background, or visible text), dimming function, and display cap segmentation for each specific application.

3.11.1 Discernability

Installer shall be responsible for installing the unit in such a manner as to prevent obscuration or confusion of task essential information.

3.11.2 Critical Information

Installer shall specify the task essential information on the display cap to prevent the removal (or lack of display) of information deemed critical to safe aircraft operation.

3.11.6 Lighting

The DCU120-S can be specified with a variety of lighting colors, display types, and dimming functions. Installer shall be responsible for specifying the appropriate lighting colors, display types, and dimming function for each specific application such that all instrument markings are clearly visible to the appropriate crew member in all appropriate lighting conditions.

Section 4: Limitations

Section references below refer to AS8034 which contain the performance standards for TSO C113b.

4.1 Equipment Functions and Mechanical Operation

4.1.1 Viewing Envelope: The DCU120-S shall be viewed from a distance of 6 feet, at all angles up to 40° to a line perpendicular to the center of the viewing surface. Installer shall be responsible for installation location. The DCU120-M1, -B and -S do not contain a viewable display.

4.3.4 Color

Installer shall be responsible to ensure that the colors used in the display caps to be installed in all types of aircraft (Part 23, 25, 27, and 29) meet the requirements in 14 CFR 25.1322 and the guidance in AC 25.1322.

4.3.2.1 Manual Luminance Control

The DCU can be specified with variable voltage dimming or discrete dimming with two or three levels of dimming accessible by changing the input on two control pins. The Installer shall be responsible for selecting the appropriate luminance control.

Section 5: Functional Description

Configuration File (CF)

The DCU120-[] is a highly configurable device. Its operational behavior is determined by a configuration file which is created by Applied Avionics based on customer specifications. There are a well-defined and limited number of configurable behaviors in the configuration file. The DCU120-[] is always configured at the factory and tested against its specific customer specifications using the configuration file before shipping. It is not field loadable or operator configurable, nor does it contain any user-modifiable code.

Each application will have a unique set of data within the CF and the fielded DCU120 will have a unique part number. The specifics of the CF represent the customer configuration for a given application. The CF is loaded in internal flash memory in the DCU120.

The configuration of each DCU120 version is defined by the customer or the aircraft integrator via an iterative process with Applied Avionics personnel. The customer or integrator delineates the capabilities and defines the application specification, but Applied Avionics creates and controls the resulting CF for them. Fielded DCU120s are loaded with their CF at the time of manufacture and tested prior to delivery to meet the customer or integrator's intended application specification. Customers and integrators retain responsibility of their application specification and accept the delivered DCU120 per their planned processes.

Inputs and Outputs

ARINC 429

The DCU120 contains two ARINC 429 input channels and one ARINC 429 output channel. The DCU can be specified with a maximum of 100 labels per channel and can be specified to access any single bit or bit string within a given label. Each channel can be specified for high speed or low speed, parity bit handling, and SDI bit handling.

Discrete Inputs

The DCU120-S and DCU120-M1 have up to nine discrete inputs while the DCU120-B has up to twenty-three discrete inputs.

At the DCU120 external connector, the discrete input may be a) ground / open or b) open / 28VDC. Each active input must be specified to be Pulled-Up or Pulled-Down when floating.

DCU120-S Specific Inputs and Outputs

The DCU120-S can be specified with up to three external connections that connect directly to the illuminated cap. The cap functions driven by these connections include an Illumination Test (available regardless of the DCU being powered up), providing display cap illumination power, and cap dimming control.

Additionally, the DCU120-S can be specified with an internal momentary switch in lieu of being an indicator only. Pressing the illuminated cap will activate the momentary switch, producing an additional Discrete Input to the microcontroller.

The DCU120-S illuminated cap can be illuminated by 1 to 4 (based on the cap's illumination circuit) internal ground signals. For each of the signals used to illuminate the cap, a specific external pin will be grounded at the same time. The cap's illumination circuit will be specified in the CF.

Analog Inputs

The DCU120 has eight analog inputs which are connected to analog input pins on the microcontroller. All analog inputs can read a -11 to 32.0 VDC input.

The DCU120 Configuration File allows any Analog Input to instead be used as a Discrete Input in software by setting threshold voltages for the high and low states.

Discrete Outputs

The DCU120-S and DCU120-M1 have up to eight discrete outputs while the DCU120-B has sixteen discrete outputs.

On the DCU120-B all discrete outputs drive their signals to external connector pins.

On the DCU120-M1 and DCU120-S, some discrete output channels may be reassigned as discrete inputs. On the DCU120-S with integral display, a Discrete Output must be used in conjunction with each cap segment required.

All of the Discrete Outputs are rated at 0.25A Maximum. One specific output can be used with 0.50A-rated loads.

RS-232

The DCU120 contains a single RS-232 receive and transmit channel.

Failure Detect and Health Indicator Output

The DCU120 has a failure detection circuit that is independent from the microcontroller and which also has an external output signal which can indicate DCU120 failure to external equipment. The failure indicator signal is also monitored by the OFP software via a microcontroller GPIO pin so that even a failure of the watchdog reset signal is detected. The Health Pin (Pin 31) will Fail Open.

Section 6: Non-TSO Functions

TSO C113b points to meeting the objectives of Sections 3 and 4 of SAE AS8034C which mostly describes requirements for display quality and not display function. Display function is covered by a general statement in AS8034C Section 4.1 that states “All equipment functions and mechanical devices shall perform their intended function.” The DCU120 provides signal processing functions that drives data to the display. These are in the form of non-TSO functions.

The purpose of the Section is to address the requirements of Section 5(f)(1) – 5(F)(4) of TSO-C113b as noted below:

TSO Ref.	TSO Description
5(f)	Identify functionality or performance contained in the article not evaluated under paragraph 3 of this TSO (that is, non-TSO functions). Non-TSO functions are accepted in parallel with the TSO authorization. For those non-TSO functions to be accepted, you must declare these functions and include the following information with your TSO application
5(f)(1)	Description of the non-TSO function(s), such as performance specifications, failure condition classifications, software, hardware, and environmental qualification levels. Include a statement confirming that the non-TSO function(s) don't interfere with the article's compliance with the requirements of paragraph 3
5(f)(2)	Installation procedures and limitations sufficient to ensure that the non-TSO function(s) meets the declared functions and performance specification(s) described in paragraph 5.f.(1).
5(f)(3)	Instructions for continued performance applicable to the non-TSO function(s) described in paragraph 5.f.(1).
5(f)(4)	Interface requirements and applicable installation test procedures to ensure compliance with the performance data defined in paragraph 5.f.(1)

The DCU120 has non-TSO functions for Data Bus Bridging and Data Concentration.

Data Bus Bridging

Data bus bridging can be accomplished by the DCU in 2 ways:

- 1) **Single DCU Data Bus Bridging:** a single DCU can be specified to transfer data from one data bus to another data bus

A429 High Speed	→	A429 Low Speed
A429 Low Speed	→	A429 High Speed
A429 Any Speed	→	RS232
RS232	→	A249 Any Speed
- 2) **Multiple Unit Data Bus Bridging:** the output of a DCU device can be the input to another DCU device. For example:
 - a. If an installation requires ARINC data from 3 distinct ARINC data busses, DCU's can be daisy-chained together as shown below:

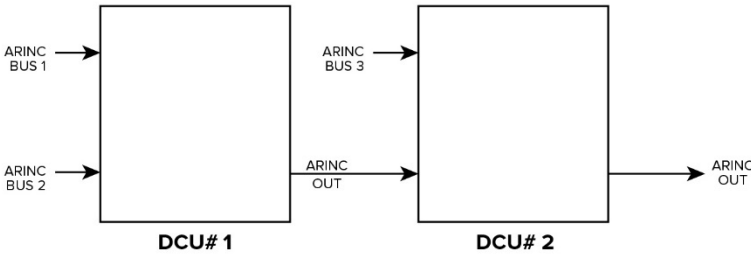

Data Concentration

An installed DCU120 system may consist of one or more DCU120 devices which interface with other aircraft systems to perform the TSO-C113b display functions and non-TSO data processing functions

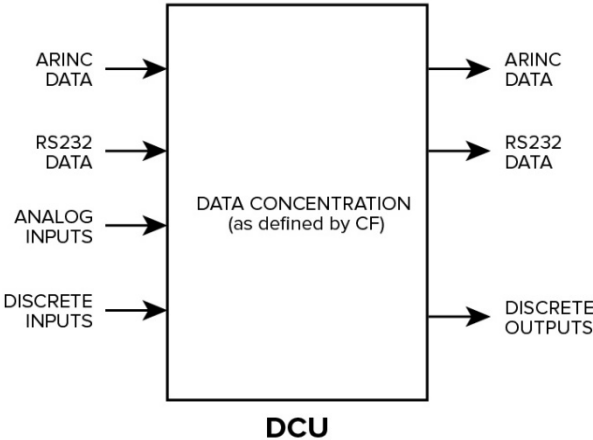

Each of the DCU120 models uses common internal hardware to manage the inputs and outputs and perform data processing. The unit performs the primary data processing function using a Commercial-Off-The-Shelf (COTS) microcontroller affixed to a circuit board. In all models, the microcontroller will have identical Operational Flight Program (OFP) software loaded that can perform a wide variety of well-defined operations in accordance with a custom configuration file. For each specific unique application, this factory set Configuration File will provide the specific input, processing, and output configuration to the core software. Because of physical size constraints, the number of I/O signals varies slightly by model.

When the configuration file is created for each customer, it specifies which input, output, and data buses are used and what data processing operations are performed on data to and from those interfaces. The OFP only performs the processing specified by the configuration file, and the configuration file will only use I/O channels available on the DCU120 form factor ordered by that customer.

These non-TSO functions are developed and verified to the same DAL level as the TSO-related functions and are qualified with the same environmental requirements. These functions are described in detail by the DCU120 System Requirements and are all verified through requirements-based testing. The System Verification Results (AAI-DCU120-DOC-SysVR) will substantiate the verification activities for these functions and provide proof that they do not interfere with the DCU120's compliance with the requirements of the TSO.

Installation procedures and limitations for the non-TSO functions are the same as the TSO functions and are covered in Section 3.

Instructions for continued performance for the non-TSO functions are the same as the TSO functions and are covered in Section 7.

For the non-TSO functions, interface requirements, and applicable installation test procedures to meet the customer or integrator's intended application specification are completed at the time of manufacture prior to delivery.

Section 7: Continued Airworthiness

There are no regularly recurring (maintenance) Installer responsibilities to allow continued airworthiness. It is recommended that the unit be replaced after 100,000 operating flight hours.

- There is no scheduled maintenance.
- The units should be replaced after 100,000 operating flight hours.
- There are no field-loadable software or configuration changes that can be made in the field.
- Opening the unit will void any warranty.

Open Problem Reports (OPRs) will be provided in the document Open Problems Report Summary AAI-DCU120-DOC-OPR. The document includes the process of reporting, entering, and dispositioning OPRs found in the field. Applied Avionics will provide OPR updates and support for the installation approval holder.

APPENDIX A – Top Level Assembly Drawings

REV	DESCRIPTION	APPROVAL	DATE
A	PRODUCTION RELEASE ECR 4466 HUMPHREYS	R VAZQUEZ J McELROY	9-21-22 9/22/22
B	CAP AND BODY MOVED TO THEIR OWN DRAWINGS ECR 4520 HUMPHREYS	J McELROY S EDWARDS	9 FEB 2023 8 FEB 2023
C	ADD NOTE TO CLARIFY PART NUMBERING SYNTAX ECR 4535 HUMPHREYS	J McELROY S EDWARDS	1 MAR 2023 28 FEB 2023
D	CLARIFY TSO MARKING ECR 4540 HUMPHREYS	R VAZQUEZ S EDWARDS	24 MAR 2023 24 MAR 2023

DCU120-S-XXXXX		
ITEM	PART NUMBER	DESCRIPTION
1	DCU120-S-XXXXX-BDY	DCU120-S BODY ASSEMBLY
2	28602	CONNECTOR PLUG (OPTIONAL)
3	LED-XX-WW-YYY-ZZZZ	CAP

NOTE 1: FINAL ASSEMBLY HAS P/N SYNTAX DCU120-S-XXXXX, WHERE EACH "X" IS AN ALPHANUMERIC CHARACTER. EACH STRING OF FIVE (5) CHARACTERS IS A UNIQUE COMBINATION THAT CAN BE USED TO ACCESS ALL ADDITIONAL DETAILS FOR A SPECIFIC PART, INCLUDING THE SWITCH BODY (ITEM 1), INCLUSION/EXCLUSION OF CONNECTOR PLUG (ITEM 2), AND ILLUMINATED CAP (ITEM 3).

NOTE 2: FOR ITEM 3 (CAP), THE "XX" IS A PART OF THE PART NUMBER, IT IS NOT A PLACEHOLDER FOR ADDITIONAL PART INFORMATION. THE "WW" AND "YYY" ARE ALPHANUMERIC CHARACTERS THAT DEFINE THE ENCLOSURE TYPE, DISPLAY STYLE, SWITCH ACTION, AND BRICK REQUIRED FOR THE SPECIFIC CAP CONFIGURATION REQUIRED. EACH "Z" IS AN ALPHANUMERIC CHARACTER, AND EACH STRING OF 5 CHARACTERS IS A UNIQUE COMBINATION THAT CAN BE USED TO ACCESS ALL ADDITIONAL DETAILS FOR THE CAP CONFIGURATION REQUIRED, INCLUDING THE LIGHTING TYPE, ILLUMINATION COLOR, AND LEGEND (TEXT, FONT, AND FONT HEIGHT).

NOTE 3: SIDE OF BODY SHALL BE MARKED WITH PART NUMBER, BOARD SERIAL NUMBER, DATE CODE, TSO-C113b INCOMP, AND MANUFACTURER INFORMATION.

UNLESS OTHERWISE NOTED DIMENSIONS ARE IN INCHES AND TOLERANCES ON		APPD	J McELROY	9/22/2022	APPLIED AVIONICS, INC.	
		CHK BY	R VAZQUEZ	9/21/2022	3201 SANDY LANE FORT WORTH, TEXAS 76112	
DECIMALS	ANGLES	DRAWN BY	M Humphreys	5/22/2020	DCU120-S TOP LEVEL ASSEMBLY	
.XX #		THIRD ANGLE PROJECTION:				
.XXX #					CODE IDENT NO	
MATERIAL	PROPRIETARY DRAWING				32245	SIZE B
		THIS DOCUMENT CONTAINS PROPRIETARY INFORMATION AND IS NOT TO BE RELEASED OR REPRODUCED WITHOUT THE WRITTEN PERMISSION OF APPLIED AVIONICS, INC.			DCU120-S-XXXXX	SCALE
					REV SYM D	SHEET 1 OF 1

APPENDIX A - CONTINUED

Parts List			
ITEM	QTY	PART NUMBER	DESCRIPTION
1	OPTIONAL	28602	CONNECTOR PLUG (SEE NOTE 1)
2	1	22032	DCU120-M1 HOUSING
3	1	AAI-DCU120-OPP-001	OPP LOAD ONTO MICROPROCESSOR
4	1	AAI-DCU120-CF-##	CUSTOMER SPECIFIC CONFIGURATION FILE
5	AS NEEDED	18048	KAPTON TAPE
6	1	28704-XXXXXXXXXX	DCU120-S,M1 CUBE ASSY
7	1	20028	SILICONE ADHESIVE

REV	DESCRIPTION	APPROVAL	DATE
A	PRODUCTION RELEASE ECR 4467 HUMPHREYS	J McELROY S EDWARDS	19 SEPT 2022 8 SEPT 2022
B	ADD MARKING INFORMATION AND FACE SEAL ECR 4519 HUMPHREYS	R VAZQUEZ S EDWARDS	17 JAN 2023 17 JAN 2023
C	DEFINE SPECIFIC VERSION OF THE OPP ECR 4528 HUMPHREYS	J McELROY S EDWARDS	9 FEB 2023 9 FEB 2023
D	MOVE FACE SEAL TO CUBE ASSEMBLY. ADD NOTE TO CLARIFY PART NUMBER SYNTAX ECR 4535 HUMPHREYS	J McELROY S EDWARDS	1 MAR 2023 28 FEB 2023
E	CLARIFY TSO MARKING ECR 4540 HUMPHREYS	R VAZQUEZ S EDWARDS	24 MAR 2023 24 MAR 2023
F	28604 CONNECTOR PLUG IS MARKED 28602 ECR 4591 HUMPHREYS	S EDWARDS S EDWARDS	7/14/23 7/14/23

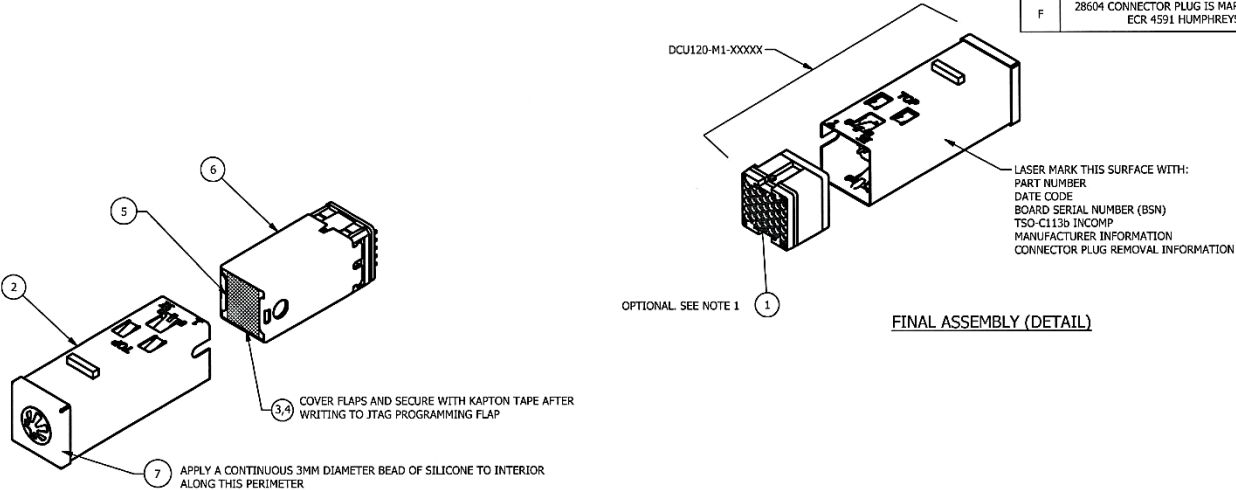

LASER MARK THIS SURFACE WITH:
PART NUMBER
DATE CODE
BOARD SERIAL NUMBER (BSN)
TSO-C113d INCOMP
MANUFACTURER INFORMATION
CONNECTOR PLUG REMOVAL INFORMATION

FINAL ASSEMBLY (DETAIL)

COVER FLAPS AND SECURE WITH KAPTON TAPE AFTER WRITING TO JTAG PROGRAMMING FLAP

APPLY A CONTINUOUS 3MM DIAMETER BEAD OF SILICONE TO INTERIOR ALONG THIS PERIMETER

NOTE 1: PART NUMBERING: PART NUMBER HAS SYNTAX DCU120-M1-XXXXX, WHERE EACH X IS AN ALPHANUMERIC CHARACTER. EACH STRING OF FIVE (5) CHARACTERS IS A UNIQUE COMBINATION THAT CAN BE USED TO ACCESS ALL ADDITIONAL PART DETAILS FOR A SPECIFIC PART, SUCH AS CONFIGURATION FILE (ITEM 4), CUBE ASSEMBLY (ITEM 6), AND INCLUSION/EXCLUSION OF CONNECTOR PLUG (ITEM 1)
NOTE 2: FOR ITEM 6, EACH OF THE "X" POSITIONS FOLLOWING THE 28704- DESCRIBES A PARTICULAR PHYSICAL BUILD (PLACEMENT OR REMOVAL OF A JUMPER) THAT CONFIGURES THE CUBE ASSY TO MATCH THE REQUIREMENTS OF ITEM 4 (CUSTOMER SPECIFIC CONFIGURATION FILE). REFER TO DWG 28704-XXXXXXXXXXXX.
NOTE 3: FOR ITEM 4, THE "##" REPRESENTS A UNIQUE FILE NAME OR FILE NUMBER (MAXIMUM OF 10 ALPHANUMERIC CHARACTERS) REFERRING TO A SPECIFIC VERSION OF A CONFIGURATION FILE GENERATED AND LOADED AT THE TIME OF MANUFACTURE.
NOTE 4: PRESS CUBE ASSEMBLY FULLY INTO HOUSING ASSEMBLY. ENSURE THAT RETAINING TABS ARE SEATED 4 PLS

UNLESS OTHERWISE NOTED DIMENSIONS ARE IN INCHES AND TOLERANCES ON		APPD	J McELROY	19 SEPT 2022	APPLIED AVIONICS, INC.	
		CHK BY	S EDWARDS	8 SEPT 2022	3201 SANDY LANE FORT WORTH, TEXAS 76112	
DECIMALS	ANGLES	DRAWN BY	M Humphreys	5/26/2020	DCU120-M1 TOP LEVEL ASSEMBLY	
.XX ±		THIRD ANGLE PROJECTION:		CODE IDENT NO 32245		
.XXX ±						
MATERIAL		PROPRIETARY DRAWING			SIZE	B
		THIS DOCUMENT CONTAINS PROPRIETARY INFORMATION AND DESIGNS OWNED BY APPLIED AVIONICS, INC. NEITHER THIS DOCUMENT NOR ANY PART OF THIS DOCUMENT MAY BE DISCLOSED OR REPRODUCED IN WHOLE OR IN PART WITHOUT THE WRITTEN PERMISSION OF APPLIED AVIONICS, INC.			REV	SYM F
					SCALE	SHEET 1 OF 1

APPENDIX A - CONTINUED

Parts List			
ITEM	QTY	PART NUMBER	DESCRIPTION
1	1	2706052	BOX FOR DCU120-B COMPLETE
2	1	27063	COVER WITH GASKET
3	2	27012	JACKSCREW- FEMALE 806-JSX-1000
4	4	27014	SCREW M4X.7X16MM
5	5	27017	SCREW 4-40 X .25 TORX SS
6	1	17148	SILICONE RTV108
7	1	27304-XXXXXXXXXX	DCU120-B PCB ASSEMBLY CONFIGURED AND TESTED
8	2	27065	TAMPER LABEL
9	AS NEEDED	330-2XP-00011-022	LOCTITE 262
10	1	AAI-DCU120-OFF-001	OFF LOAD ONTO MICROPROCESSOR
11	1	AAI-DCU120-CF-##	CUSTOMER CONFIGURATION FILE

REV	DESCRIPTION	APPROVAL	DATE
A	PRODUCTION RELEASE ECR 4468 HUMPHREYS	J McELROY S EDWARDS	15 SEPT 2022 7 SEPT 2022
B	ITEM 1 RE-NAMED, FILE LOADS MOVED TO THIS LEVEL ECR 4481 HUMPHREYS	J McELROY D BRILLHART	11 OCT 2022
C	REPLACE GASKET 27016 WITH RTV 17148 ECR 4485 HUMPHREYS	J McELROY D BRILLHART	26 OCT 2022 26 OCT 2022
D	DEFINE SPECIFIC VERSION OF THE OFF ECR 4528 HUMPHREYS	J McELROY S EDWARDS	9 FEB 2023 9 FEB 2023
E	ADD NOTE CLARIFYING PCB NUMBERING SYNTAX ECR 4535 HUMPHREYS	J McELROY S EDWARDS	1 MAR 2023 28 FEB 2023
F	CLARIFY TSO MARKING ECR 4540 HUMPHREYS	R VAZQUEZ S EDWARDS	24 MARCH 2023 24 MARCH 2023

DCU120-B FINAL ASSEMBLY
SCALE 1 / 2

APPLY LABEL OVER SEAM AS SHOWN 2 PLS

APPLY AROUND BASE OF DSUB FLANGE

LASER MARK THIS SURFACE WITH:
PART NUMBER
DATE CODE
BOARD SERIAL NUMBER(BSN)
TSO-C113b INCOMP
MANUFACTURER INFO

NOTE 1: PART NUMBERS COVERED BY THIS DRAWING HAVE SYNTAX DCU120-B-XXXXX, WHERE EACH "X" CAN BE AN ALPHANUMERIC CHARACTER. EACH STRING OF FIVE (5) CHARACTERS IS A UNIQUE COMBINATION THAT CAN BE USED TO ACCESS ADDITIONAL PART DETAILS, INCLUDING THE SPECIFIC ITEM 7 USED TO MANUFACTURE DCU120-B-XXXXX

NOTE 2: FOR ITEM 7, EACH OF THE "X" POSITIONS FOLLOWING THE 27304- DESCRIBES A PARTICULAR PHYSICAL BUILD (PLACEMENT OR REMOVAL OF A JUMPER) THAT CONFIGURES THE PCB ASSY TO MATCH THE REQUIREMENTS OF ITEM 11 (CUSTOMER SPECIFIC CONFIGURATION FILE). REFER TO DWG 27304-XXXXXXXXXX.

NOTE 3: FOR ITEM 11 THE "##" REPRESENTS A UNIQUE FILE NAME OR FILE NUMBER (MAXIMUM OF 10 ALPHANUMERIC CHARACTERS) REFERRING TO A SPECIFIC VERSION OF A CONFIGURATION FILE GENERATED AND LOADED AT THE TIME OF MANUFACTURE.

UNLESS OTHERWISE NOTED DIMENSIONS ARE IN INCHES AND TOLERANCES ON	APPD	J McELROY	15 SEPT 2022	APPLIED AVIONICS, INC. 3201 SANDY LANE FORT WORTH, TEXAS 76112
	CHK BY	S EDWARDS	7 SEPT 2022	
DECIMALS	ANGLES	DRAWN BY	M Humphreys	DCU120-B TOP LEVEL ASSEMBLY
.XX ±		THIRD ANGLE PROJECTION:		
.XXX ±		Ⓢ		CODE IDENT NO 32245
MATERIAL	PROPRIETARY DRAWING			SIZE B
THIS DOCUMENT CONTAINS PROPRIETARY INFORMATION AND DESIGNS OWNED BY APPLIED AVIONICS, INC. NEITHER THIS DOCUMENT NOR ANY PART OF THIS DOCUMENT MAY BE DISCLOSED OR REPRODUCED IN WHOLE OR IN PART WITHOUT THE WRITTEN PERMISSION OF APPLIED AVIONICS, INC.				DCU120-B-XXXXX
SCALE		REV SYM F		SHEET 1 OF 1

APPENDIX B

Mounting and Installation Control Drawing

Models Covered:

**DCU120-S
DCU120-M1
DCU120-B**

Extracted from

FAA TSO Project SP02829AC-Q

Document No: AAI-DCU120-DOC-MICD

Revision: 02

DCU120-S MOUNTING and INSTALLATION

Dimensions:

Sealed

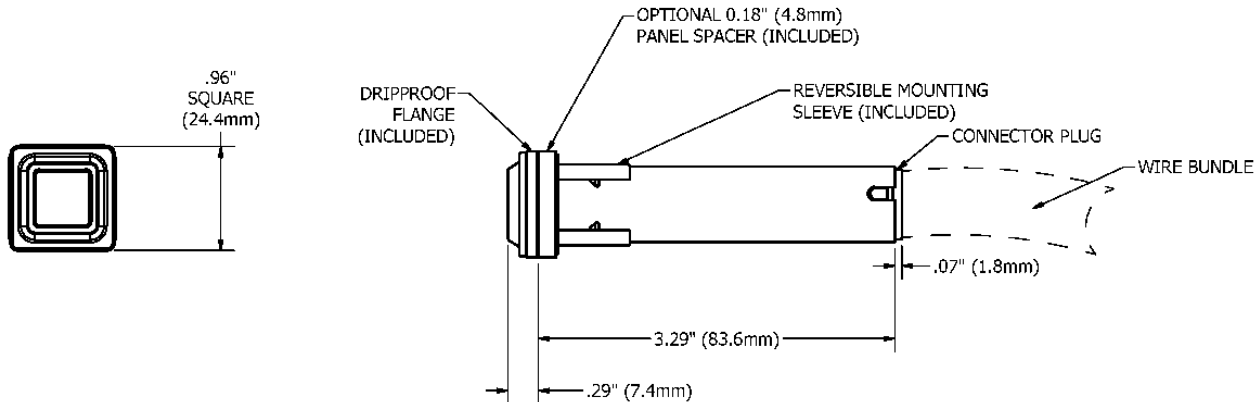

Figure S-1

Unsealed

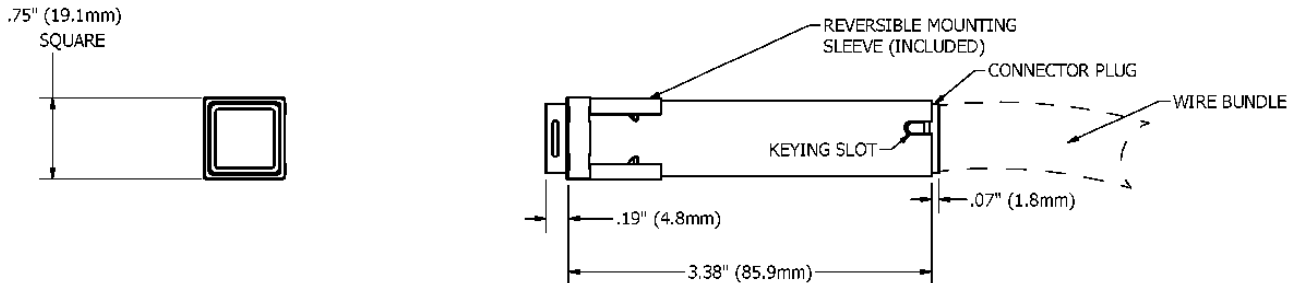

Figure S-2

Weight: Unsealed Switch (including cap and connector plug): 0.11 lbs (50 grams)
Sealed Switch (including cap and connector plug): 0.12 lbs (53 grams)

Clearance:

The panel cutout dimensions below prescribe the required clearance between switches.

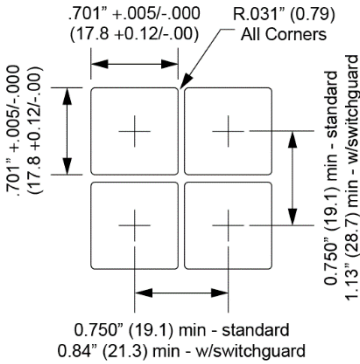

Figure S-3 Unsealed Switch

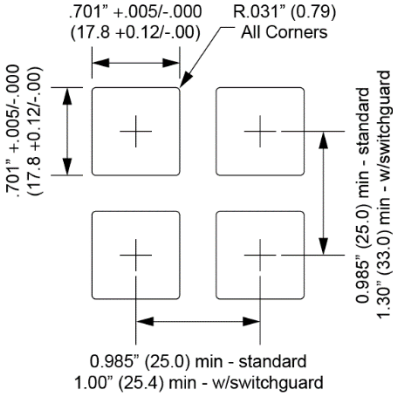

Figure S-4 Sealed Switch

Mounting: Switch Assembly with Unsealed Cap

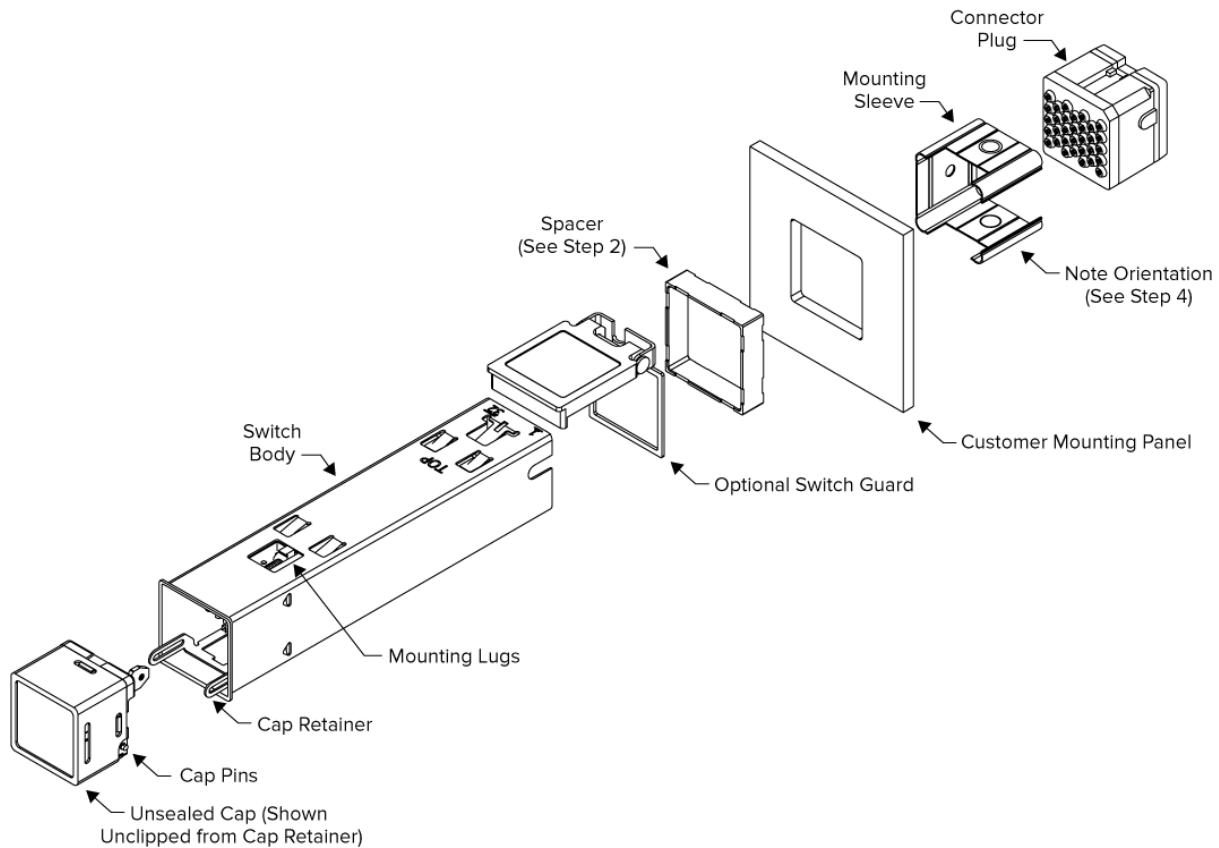

Figure S-5

Step 1: Ensure cap is in the unlatched position and gently extract cap from switch body using the two extraction slots on side of cap. A Cap Extractor Tool (AAI P/N 17-150) may be used. Remove cap from switch body by gently removing the cap pins from the cap retainer.

Step 2: For flush panel mounting, remove the mounting sleeve and mounting spacer and discard mounting spacer. For extended projection mounting (i.e., with edgelit panel), remove the mounting sleeve only and retain mounting spacer on switch body (will be captured between flange and mounting panel).

Step 3: Insert switch body into panel cutout with “TOP” (marked on body) facing up.

Step 4: From behind the mounting panel, replace the mounting sleeve. For flush panel mounting, ensure that the rectangular cutouts are facing the panel and that the “open” side of the mounting sleeve is on one side of the body, not on the top or bottom. For extended projection mounting (i.e., with edgelit panel), ensure that the rectangular cutouts are facing away from the panel and that the “open” side of the mounting sleeve is on one side of the body, not on the top or bottom.

Step 5: From the front of the switch body locate the slot head integral mounting screws in the base of the body. Tighten the two screws clockwise until both mounting lugs pull the mounting sleeve against the panel. Recommended torque is 18–25-inch ounces.

Step 6: Replace the cap. The cap bezel contains two retention pins which should be hooked onto the ends of the metallic sliding retainer. Both pins should be captured by the retainer. Rotate, insert probe pin into slot in body, and push gently. Cap is keyed via a pin on the probe to prevent incorrect insertion.

Step 7: Wire the connector plug (AAI P/N 28-602) per customer application before inserting into the body to ensure proper seating of sockets. The solderless connector plug accepts AMPHENOL AEROSPACE 2M809-002 (type 23) sockets crimped onto 22 to 28 gauge wire without soldering. These sockets are not included with connector plugs and must be ordered separately (AAI P/N 28-619). Crimped wires are inserted into and extracted from the connector plug by use of a GLENAIR 809-088 tool.

Step 8: Install the connector plug in switch body. No tool is necessary to insert the connector plug into the back of the switch body. Connector plug is keyed to prevent incorrect insertion. The connector plug should be inserted until both of the locking tabs “click” into position. Test that the connector plug is properly inserted and retained in the body by tugging on the wire bundle.

Removal of the connector plug from the back of the switch body requires a connector plug extraction tool (AAI P/N 18-234) to avoid damaging the locking tabs. Manually spreading the locking tabs without using the specified tool will prevent proper retention of connector plug when it is reinserted, causing intermittent wiring contact. Connector plugs should not be removed by manually spreading the locking tabs.

Mounting Switch Assembly with Sealed Cap

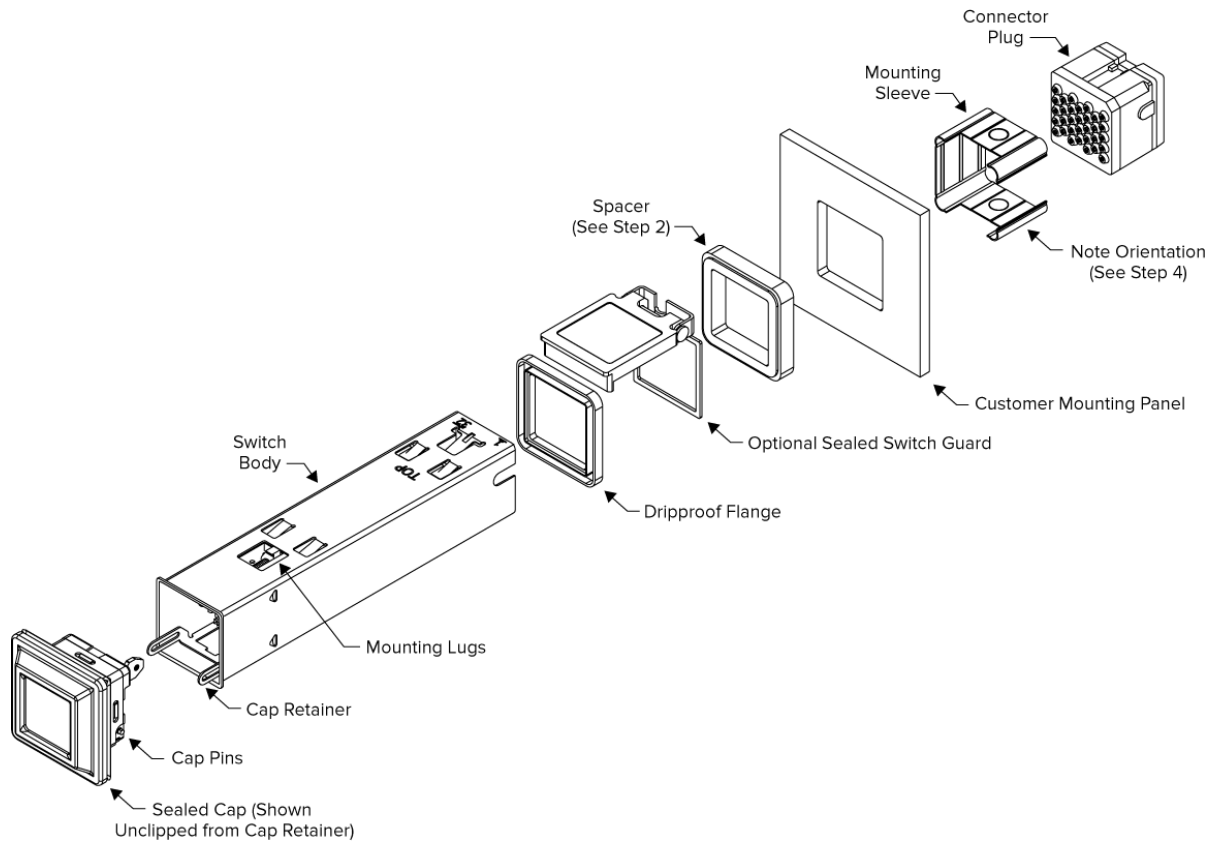

Figure S-6

Step 1: Ensure cap is in the unlatched position. Lift up the sealing gasket and gently extract cap from switch body using the two extraction slots on side of metal cap bezel. A Cap Extractor Tool (AAI P/N 17150) may be used. Remove cap from switch body by gently removing the cap pins from the cap retainer.

Step 2: For flush panel mounting, remove the mounting sleeve and mounting spacer and discard mounting spacer. For extended projection mounting (i.e., with edgelit panel), remove the mounting sleeve only and retain mounting spacer on switch body (will be captured between flange and mounting panel). Leave the dripproof flange on the switch body.

Step 3: Insert switch body into panel cutout with “TOP” (marked on body) facing up.

Step 4: From behind the mounting panel, replace the mounting sleeve. For flush panel mounting, ensure that the rectangular cutouts are facing the panel and that the “open” side of the mounting sleeve is on one side of the body, not on the top or bottom. For extended projection mounting (i.e., with edgelit panel), ensure that the rectangular cutouts are facing away from the panel and that the “open” side of the mounting sleeve is on one side of the body, not on the top or bottom.

Step 5: From the front of the switch body locate the slot head integral mounting screws in the base of the body. Tighten the two screws clockwise until both mounting lugs pull the mounting sleeve against the panel. Recommended torque is 18-25 inch ounces.

Step 6: Replace the cap. The cap bezel contains two retention pins which should be hooked onto the ends of the metallic sliding retainer. Both pins should be captured by the retainer. Rotate, insert probe pin into slot in body, and push gently. Cap is keyed via a pin on the probe to prevent incorrect insertion.

Step 7: Seal the cap onto the seal mounting flange by pressing a lower corner of the seal into the lower flange corner using firm finger pressure. Next, press each of the remaining corners of the seal into their respective flange corners. Follow by pressing each of the four sides into the seal mounting flange, ensuring all sides of the seal are fully seated.

Step 8: Wire the connector plug (AAI P/N 28-602) per customer application before inserting into the body to ensure proper seating of sockets. The solderless connector plug accepts AMPHENOL AEROSPACE 2M809-002 (type 23) sockets crimped onto 22 to 28 gauge wire without soldering. These sockets are not included with connector plugs and must be ordered separately (P/N 28619). Crimped wires are inserted into and extracted from the connector plug by use of a GLENAIR 809-088 tool.

Step 9: Install the connector plug into the back of the switch body. No tool is necessary to insert the connector plug. Connector plug is keyed to prevent incorrect insertion. The connector plug should be inserted until both of the locking tabs “click” into position. Test that the connector plug is properly inserted and retained in the body by tugging on the wire bundle.

Removal of the connector plug from the back of the switch body requires a connector plug extraction tool (AAI P/N 18-234) to avoid damaging the locking tabs. Manually spreading the locking tabs without using the specified tool will prevent proper retention of connector plug when it is reinserted, causing intermittent wiring contact. Connector plugs should not be removed by manually spreading the locking tabs.

DCU120-M1 MOUNTING and INSTALLATION

The DCU120-M1 has two distinct mounting methods: Right Angle Mounting and Rail Mounting. Each of these types of mounting are discussed below. The right-angle bracket (AAI P/N 22-005) and Rail (AAI P/N 22-006) are each sold separately by Applied Avionics, Inc.

Module - Right Angle Mounting

Dimensions:

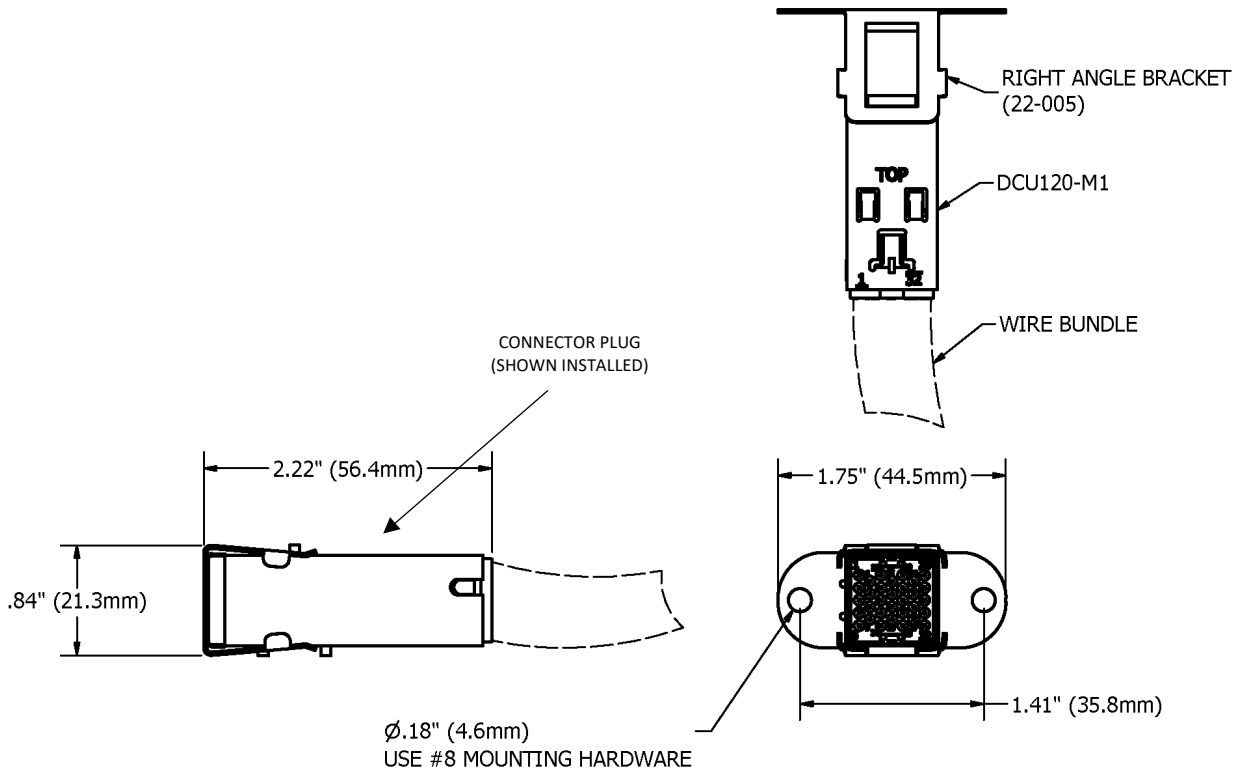

Figure M1-1

Weight: Module, bracket and, connector; 0.10 lbs (45 grams) total.

Clearance: Proper clearance for the applicable wire bundle must be provided by the installer.

Mounting:

Step 1: Position the Right Angle Mounting Bracket (AAI P/N 22-005) on a flat surface.

Step 2: Mounting holes are spaced 1.41 inches apart and accept #8 machine screws (not provided). A torque of 35 to 40 in-lb. is recommended.

Step 3: Wire the connector plug (AAI P/N 28-602) per customer application before inserting into the body to ensure proper seating of sockets. The solderless connector plug accepts AMPHENOL AEROSPACE 2M809-002 (type 23) sockets crimped onto 22 to 28 gauge wire without soldering. These sockets are not included with connector plugs and must be ordered separately (AAI P/N 28-619). Crimped wires are inserted into and extracted from the connector plug by use of a GLENAIR 809-088 tool.

Step 4: Install the connector plug in module. No tool is necessary to insert the connector plug into the back of the module body. Connector plug is keyed to prevent incorrect insertion. The connector plug should be inserted until both of the locking tabs “click” into position. Test that the connector plug is properly inserted and retained in the module by tugging on the wire bundle.

Step 5: Install wired module in bracket. Note orientation of retaining key on top of unit. Module is keyed to allow the retaining key on top of the unit to mate with the smaller opening in the bracket.

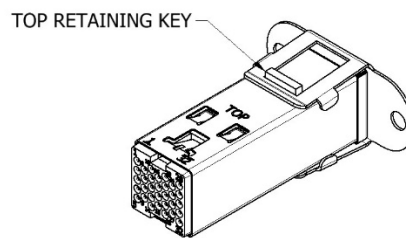

Figure M1-1

Removal of the connector plug from the back of the module requires a connector plug extraction tool (AAI P/N 18-234) to avoid damaging the locking tabs. Manually spreading the locking tabs without using the specified tool will prevent proper retention of connector plug when it is reinserted, causing intermittent wiring contact. Connector plugs should not be removed by manually spreading the locking tabs.

Module – Rail Mounting

Dimensions:

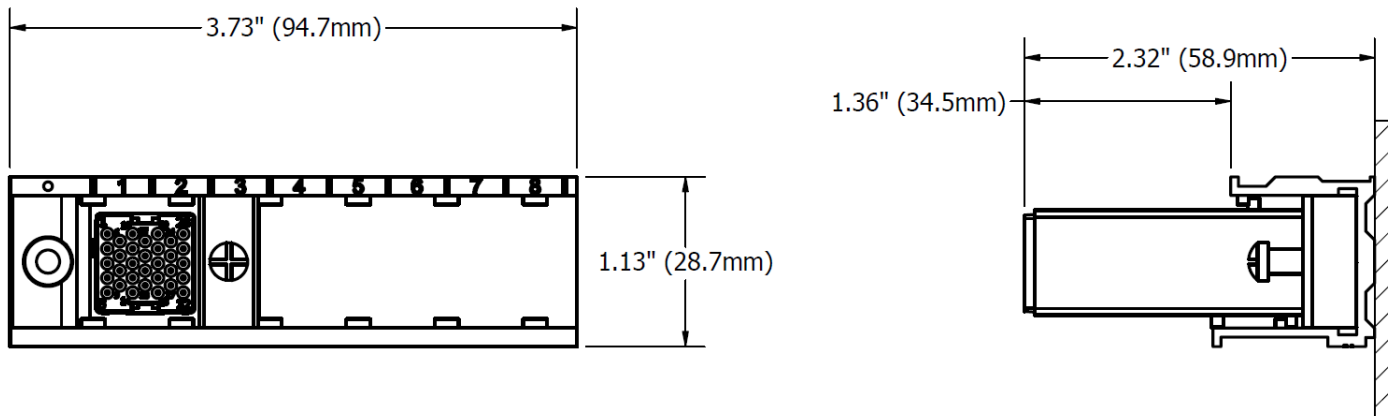

Figure M1-2

Weight: Module, connector, and rail; 0.21 lbs. (95 grams) total.

Clearance: Proper clearance for the applicable wire bundle must be provided by the installer.

Mounting:

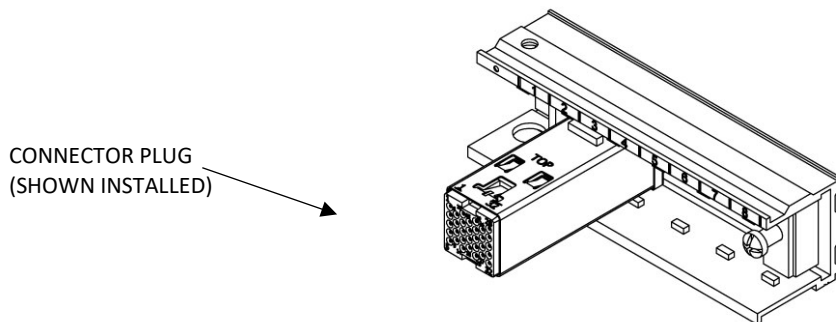

Figure M1-3

(Wires not shown for clarity)

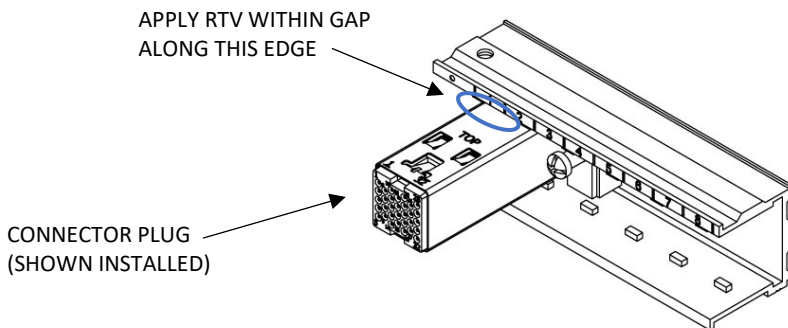

Figure M1-4

Step 1: Select an open position in the M81814 rail. Orient the top of the module housing to the top of the rail (see Figure M1-4). Slide the module against the stop and trap it with the sliding keeper. Tighten the screw in the keeper to restrain the module body (see Figure M1-5).

Step 2: Apply a 1/4-inch diameter bead of RTV between the module body and the rail to prevent buzzing and to stabilize the assembly.

Step 3: Wire the connector plug (AAI P/N 28-602) per customer application before inserting into the module to ensure proper seating of sockets. The solderless connector plug accepts AMPHENOL AEROSPACE 2M809-002 (type 23) sockets crimped onto 22 to 28 gauge wire without soldering. These sockets are not included with connector plugs and must be ordered separately (AAI P/N 28-619). Crimped wires are inserted into and extracted from the connector plug by use of a GLENAIR 809-088 tool.

Step 4: Install the connector plug in module. No tool is necessary to insert the connector plug into the back of the module body. Connector plug is keyed to prevent incorrect insertion. The connector plug should be inserted until both of the locking tabs “click” into position. Test that the connector plug is properly inserted and retained in the module by tugging on the wire bundle.

DCU120-B MOUNTING and INSTALLATION

Dimensions

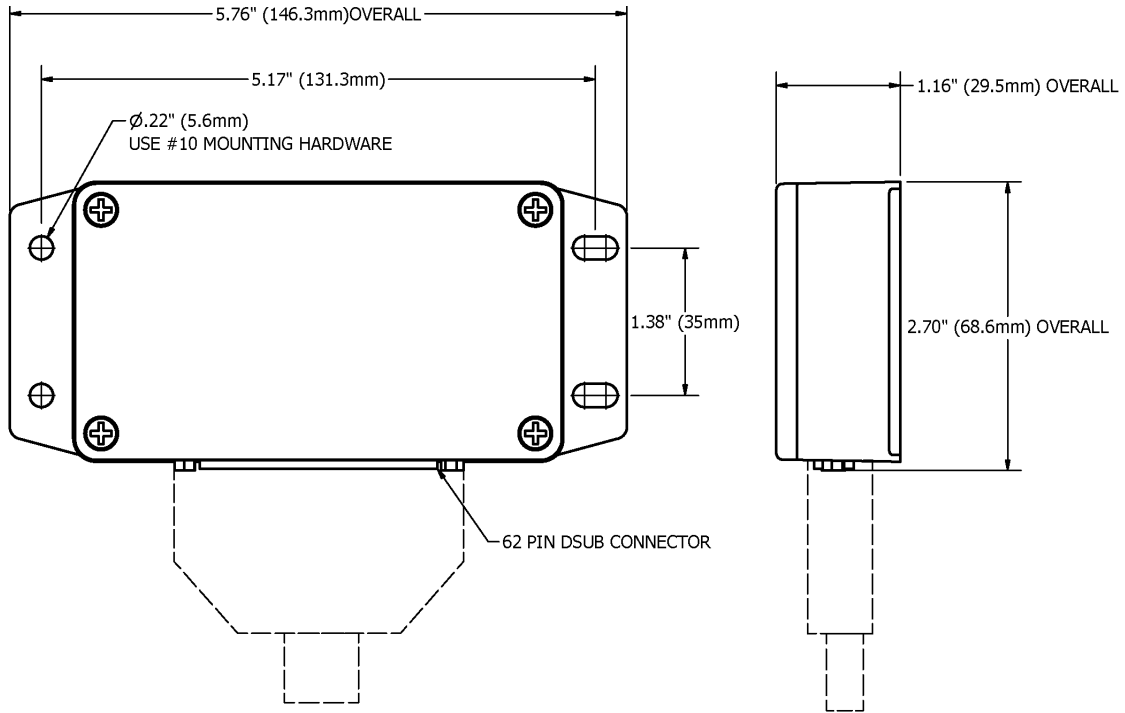

Figures B-1 and B-2

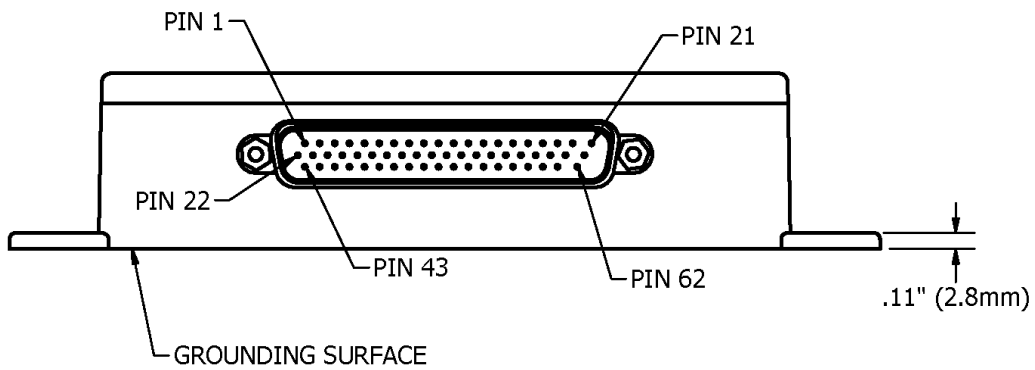

Figure B-3

Close-up of D-sub-Connector

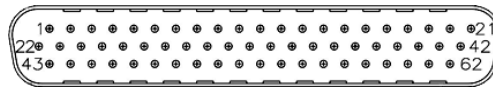

Figure B-5

Clearance: Proper clearance for the applicable D-sub connector and wire bundle must be provided by the installer.

Weight: DCU120-B is 0.60 lbs (270 grams).

Mounting:

The DCU120-B Aluminum case contains 4 through holes for anchoring the unit to a flat surface. Four #10-32 machine screws are recommended torqued to 32-35 in-lbs. The use of internal toothed #10 paint cutting lock washers is also recommended and The DCU120-[] case should be mounted on a flat surface with <0.04 inch maximum distortion as these will ensure proper physical ground.

Mating connector should be gold plated socket type 62 pin D-sub and must be provided by the installer.

Appendix C – Pinout by Model

DCU120-S		
Pin #	Description	Notes
1	ARINC 429 RX 1A	
2	ARINC 429 RX 1B	
3	ARINC 429 RX 2A	
4	ARINC 429 RX 2B	
5	ARINC 429 TX 1A	
6	ARINC 429 TX 1B	
7	Illum. Test or Discrete In	Pins not required for cap illumination may be specified as Discrete In
8	Cap Common G or Discrete In	
9	Cap Common F or Discrete In	
10	Discrete In or Discrete Out	Pins must be specified as either Discrete In or Discrete Out
11	Discrete In or Discrete Out	
12	Discrete In or Discrete Out	
13	Discrete In or Discrete Out	
14	Discrete Out (w/Cap Seg. A opt.)	Discrete Outs may be specified to also illuminate cap segments when active. The internal Cap Circuit will determine which portions of a cap are illuminated by each cap segment.
15	Discrete Out (w/Cap Seg. B opt.)	
16	Discrete Out (w/Cap Seg. C opt.)	
17	Discrete Out (w/Cap Seg. D opt.)	
18	Unit Ground	REQUIRED CONNECTION
19	Unit Ground	REQUIRED CONNECTION
20	RS 232	
21	RS 232	
22	Unit Power (+28 VDC)	REQUIRED CONNECTION
23 - 30	Analog / Discrete In	Pins may be specified as Analog In or Discrete In
31	Health Output	
32	Discrete In or Discrete Out	Pin must be specified as either Discrete In or Discrete Out

DCU120-S 32 Pin Connector Plug:

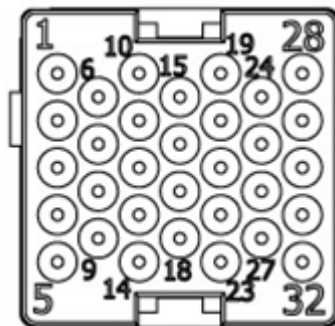

Appendix C – Pinout by Model (con't)

DCU120-M1		
Pin #	Description	Notes
1	ARINC 429 RX 1A	
2	ARINC 429 RX 1B	
3	ARINC 429 RX 2A	
4	ARINC 429 RX 2B	
5	ARINC 429 TX 1A	
6	ARINC 429 TX 1B	
7	Discrete In	
8	Discrete In	
9	Discrete In	
10	Discrete In or Discrete Out	Pins must be specified as either Discrete In or Discrete Out
11	Discrete In or Discrete Out	
12	Discrete In or Discrete Out	
13	Discrete In or Discrete Out	
14	Discrete Out	
15	Discrete Out	
16	Discrete Out	
17	Discrete Out	
18	Unit Ground	REQUIRED CONNECTION
19	Unit Ground	REQUIRED CONNECTION
20	RS 232	
21	RS 232	
22	Unit Power (+28 VDC)	REQUIRED CONNECTION
23 - 30	Analog / Discrete In	Pins may be specified as Analog In or Discrete In
31	Health Output	
32	Discrete In or Discrete Out	Pin must be specified as either Discrete In or Discrete Out

DCU120-M1 32 Pin Connector Plug:

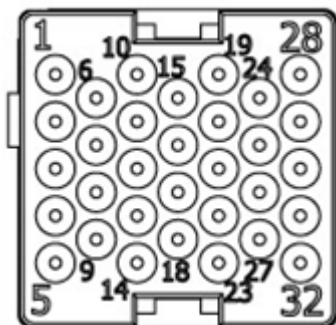

Appendix C – Pinout by Model (con't)

DCU120-B		
Pin #	Description	Notes
1	ARINC 429 RX 1A	
2	ARINC 429 RX 1B	
3	ARINC 429 RX 2A	
4	ARINC 429 RX 2B	
5	ARINC 429 TX 1A	
6	ARINC 429 TX 1B	
7	Discrete In	
8	Discrete In	
9	Discrete In	
10	Discrete Out	
11	Discrete Out	
12	Discrete Out	
13	Discrete Out	
14	Discrete Out	
15	Discrete Out	
16	Discrete Out	
17	Discrete Out	
18	Unit Ground	REQUIRED CONNECTION
19	Unit Ground	REQUIRED CONNECTION
20	NO CONNECT	
21	NO CONNECT	
22	Unit Power (+28 VDC)	REQUIRED CONNECTION
23 - 30	Analog / Discrete In	Pins may be used as Analog In or Discrete In
31	Health Output	
32	Discrete Out	
33	Discrete In	
34	Discrete In	
35 - 42	Discrete Out	
43 - 58	Discrete In	
59	Discrete In	
60	Discrete In	
61	RS 232	
62	RS 232	

DCU120-B 62 Pin D-sub Connector:

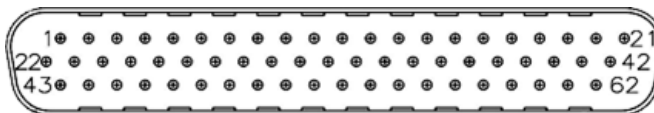

APPENDIX D – Performance Standards

The performance specifications of TSO-C113b are contained in SAE AS8034C. As an Incomplete TSO, here are the applicable paragraphs of AS8034 is qualified to. A separate table is provided for each model. The DO-160 qualification contained SAE AS8034C Section 5 in are listed in Appendix E.

DCU120-S	
Paragraph	Paragraph Text
3.1	Material
3.2	Workmanship
3.4	Interchangeability
3.6	Self-Test Capability
3.7	Effect of Tests
3.8.1	Malfunction Indication
3.8.2	Power Failure Indication
3.8.3	Fail Safe Provision
3.10	Identification
3.11	Display
3.11.1	Discernability
3.11.2	Critical Information
3.11.3	Information Limit Indication
3.11.6	Lighting
3.12	Resistance to Dust and Moisture
3.13	Mechanical Hazard System Protection
4.1	Equipment Functions and Mechanical Operation
4.1.1	Viewing Characteristics
4.2	Viewing Angle
4.2.9	Image Retention
4.2.10	Defects
4.3.1	Ambient Illumination Characteristics
4.3.2	Luminance Characteristics
4.3.2.1	Manual Luminance Control
4.3.2.3	Luminance Tracking
4.3.2.4	Luminance Uniformity
4.3.3	Luminance and Color Discrimination
4.3.4	Color
4.3.4.1	Color Uniformity
4.6	Operating Time
4.6.1	Start-Up
4.6.1.1	Power Transient Recovery

DCU120-M1	
Paragraph	Paragraph Text
3.1	Material
3.2	Workmanship
3.4	Interchangeability
3.6	Self-Test Capability
3.7	Effect of Tests
3.8.1	Malfunction Indication
3.8.2	Power Failure Indication
3.8.3	Fail Safe Provision
3.10	Identification
3.13	Mechanical Hazard System Protection
3.15	Supplemental Heating/Cooling
4.0	Min Perf Standards
4.1	Equipment Functions and Mechanical Operation
4.6.1	Start-Up
4.6.1.1	Power Transient Recovery

DCU120-B	
Paragraph	Paragraph Text
3.1	Material
3.2	Workmanship
3.4	Interchangeability
3.6	Self-Test Capability
3.7	Effect of Tests
3.8.1	Malfunction Indication
3.8.2	Power Failure Indication
3.8.3	Fail Safe Provision
3.10	Identification
3.13	Mechanical Hazard System Protection
4.0	Min Perf Standards
4.1	Equipment Functions and Mechanical Operation
4.6.1	Start-Up
4.6.1.1	Power Transient Recovery

APPENDIX E – Environmental and Electrical Qualification Levels

Each of the models meets the following DO-160G qualification levels unless noted otherwise:

Section 4	Cat F2 / A2	Temperature and Altitude
Section 5	Cat S2	Temperature Variation
Section 6	Cat B	Humidity
Section 7	Cat B	Operational Shock and Crash Safety
Section 8	Cat R & U	Vibration
Section 9	Cat E	Explosive Atmosphere
Section 10	Cat Y	Waterproofness
Section 12	Cat D	Sand and Dust
Section 13	Cat F	Fungus Resistance
Section 14 (1)	Cat T	Salt and Fog
Section 15	Cat Z	Magnetic
Section 16	Cat A	Power Input
Section 17	Cat A	Voltage Spike
Section 18	Cat Z	Audio Frequency Conducted Susceptibility
Section 19	Cat CW	Induced Signal
Section 20	Cat Y	RF Susceptibility
Section 21	Cat P	RF Emission
Section 22	XXK3L3	Lightning Susceptibility
Section 25	Cat A	ESD Discharge
Section 26 (2)	Cat C	Flammability
<p>(1) Applicable for DCU120-B, DCU120-M1, and DCU120-S with sealed cap. Not applicable for DCU120-S with an unsealed cap.</p> <p>(2) Applicable for DCU120-B and DCU120-M1. Not applicable for DCU120-S.</p>		